

Chemicals 683-697

Body Cleaners	684-685
Foam Insulation	686
Fuel Supplements	687-690
Parts Cleaners	691-694
Trailer & Truck Fluids	695-697

Lubricants 698-708

Grease	698-701
Lube	702-705
Oil	706-708

Paints 709-712

Coatings	709
Paints	709-710
Primers	711
Reducers & Removers	711-712
Undercoats	712

Fasteners 713-742

Bolts	713-718
Nuts	719-721
Pins	722
Rivets	723-727
Screws	728-730
Washers	731-732
Tech Guide	733-742

Sealants & Adhesives 743-759

Caulks	743-747
Sealers	748-756
Tapes	756-759

Shop Supplies 760-764

Marketing	760-764
---------------------	---------

Tools 765-778

Abrasives	765-766
Cleaners	766-767
Personal Safety	768-771
Bits	772-774
Gauges	775
Trailer Tools	776-778

Body Cleaners

Exterior

Lucas Oil Products

Slick Mist Speed Wax LUC10160



- Traditional wax; Polymer paint gloss intensifier
- Quick detail spray or spray it on between rinsing & drying for the easiest polish job
- long lasting protection
- 24 oz. / 12 per case
- Application: Use on paint surfaces or on other surfaces such as glass, chrome & vinyl decals

Lucas Oil Products

Slick Mist Tire & Trim Shine LUC10513



- Spray exclusively formulated to give tires & trim a long lasting "like-new" shine
- Removes dull, grey oxidation
- 24 oz. / 12 per case
- Application: Use on bumpers, tires, plastic, or any rubber & vinyl trim

Clean-rite® Purple Power® Industrial Strength Cleaner CHM12320P



- Heavy duty truck wash concentrate
- Penetrates, loosens and instantly washes away oil, grease and road grime
- 1 gal. / 4 per case
- Application: Specially formulated for trailers brushless cleaning of trucks and trailers

Clean-rite® Purple Power® Aluminum Brightener CHM4120P



- Professional strength cleaner & brighteners
- Cuts grease & oil stains fast
- Restores metal to new look
- 1 gal. / 4 per case
- Application: Use on wheels; Do not use on glass

LUCAS OIL

Chemicals

SHP

More Information

Material Safety Data Sheet

Information:

SDS documents give detailed information about the nature of a chemical, such as physical and chemical properties, health, safety, fire, and environmental hazards of a chemical product.

Current:

Visit www.MyAuroraPlus.com to download up-to-date SDS Sheets. Found under the Inquiries tab.

SDS Contains:

- Chemical Identity
- Manufacturer's Information
- Hazardous Ingredients
- Physical/Chemical Characteristics
- Fire & Explosion Hazard Data
- Reactivity Data
- Health Hazard Data
- Precautions of Safe Handling & Use
- Control Measures

Body Cleaners

Interior

HydroForce Glass Cleaner
CRC14412



CRC Industries

- Professional strength glass cleaner; Aerosol
- Cuts through dirt, dust, fingerprints & haze deposits; Streak-free; Biodegradable
- 18 wt. oz. / 12 per case
- Application: Use on glass, stainless steel, polished metals, plastic, chrome & fiberglass

Slick Mist Interior Detailer
LUC10514



Lucas Oil

- Interior detailer formulated to clean & protect
- Spray on surfaces for a "like-new" look
- 24 oz. / 12 per case
- Application: Use on steering wheels, dashboards, seats, consoles, doors, & trim

Institutional Glass Cleaner
PROCH-GC01



Pro-Par

- Dissolves smudges, film, scum, smears and other soils
- Ammonia free
- 19 oz. / 12 per case
- Application: Use on windows, mirrors, glass and other glass surfaces

GUNK® Glass Cleaner
RADGC1



RSC

- All-purpose glass & hard surface cleaner
- Leaves no film or residue
- 19 oz. / 12 per case
- Application: Use on windshields, glass, mirrors, chrome, stainless steel & aluminum



Chemicals

SHP

See Trailer & Truck Fluids

Windshield

*Note: 1bdft = 1 in. x 12 in. x 12 in.

Foam Insulation

Handi-Foam

	Type	Coverage
FOMII-105	E-84 Class 1	105 bdft*
FOMII-205	E-84 Class 1	205 bdft*
FOMII-605	E-84 Class 1	605 bdft*
FOMII-12	Quick Cure	12 bdft*
FOMII-22	Quick Cure	22 bdft*



(FOMII-105 / FOMII-205)



(FOMII-22)

- Low pressure spray polyurethane foam
- Creates barrier that improves indoor air quality
- Dispensed using patented Handi-Gun® unit
- Varying coverages available
- Application: Use to fill & insulate large voids & surfaces



(FOMII-12)



(FOMII-605)

ICP Adhesives & Sealants

FROTH-PAK™ Foam Sealant

Part Number	Coverage
DOW12	12 bdft*
DOW200	200 bdft*
DOW620	620 bdft*

- Two-component, quick-cure polyurethane foam
- Provides a continuous barrier against air infiltration
- Helps seal out moisture, dust, pests and smoke
- Primarily used to seal gaps less than 4 in. wide
- Application: Use to fill cavities, penetrations and cracks



(DOW12)



(DOW200)

Dow Chemical

GREAT STUFF PRO™ Gaps & Cracks Insulating SHP48WK15



- Sprays right into gaps and cracks up to 1 in. in diameter
- Forms a long-lasting, airtight, water-resistant seal
- 12 wt oz
- Application: Adheres to wood, metal, masonry, glass and most plastics

Dow Chemical

ICP
Aurora Parts & Accessories

DOW

Chemicals

SHP

Fuel Supplements

Starting Fluid PNR5301



Penray

- Assures safe, fast, smooth start under any conditions
- Gives upper cylinder lubrication
- Saves on batteries, towing, & engine wear
- 11 oz / 12 per case
- Application: For gasoline & diesel engines

Booster & Starting Premium Starting Fluid PNR5315



Penray

- Extremely high ether content
- Gives fast & easy starts in seconds
- Saves battery, starters & engine wear
- 11 oz / 12 per case
- Application: Use in gasoline or diesel engines

Motor Medic Thrust Starting Fluid RADM3815



RSC

- Quick, smooth starting of all gasoline engines & diesel engines without glow plugs
- Effective to -65°F below zero
- 11 oz / 12 per case
- Application: Use in gasoline or diesel engines

Fuel Treatment with Injector Cleaners & Fuel Conditioner

Part Number	Size
LUC10020	5.25 oz. (24 per case)
LUC10003	1 qt. (12 per case)
LUC10013	1 gal. (4 per case)

- Allows the engine to operate at maximum efficiency
- Cleans & lubricates the carburetor & injectors
- Causes the fuel to burn more thoroughly for increased power & less fuel consumption
- Application: Formulated for both gasoline & diesel engines, carbureted or fuel injected



Fuel Injectors

Lucas Oil



Chemicals

Fuel Supplements

Fuel Injectors

Fuel Injector Cleaner PBB16-FIC



Blaster

- Treats 2 tanks of gas
- Improves gas mileage
- 13.5 fl oz / 12 per case
- Application: Clean & condition fuel injectors, fuel pumps & fuel systems

Winter

Starting Fluid PNR5301



Penray

- Assures safe, fast, smooth start under any conditions
- Gives upper cylinder lubrication
- Saves on batteries, towing, & engine wear
- 11 oz / 12 per case
- Application: For gasoline & diesel engines

Starting Fluid PNR5216



Penray

- Defrosts and melts ice from windshields, headlights and windows
- Thaws locks in extreme cold weather
- 12.3 oz / 12 per case
- Application: Use on windshields, headlights and windows

Premium Starting Fluid PNR5315



Penray

- Extremely high ether content
- Gives fast & easy starts in seconds
- Saves battery, starters & engine wear
- 11 oz / 12 per case
- Application: Use in gasoline or diesel engines

Air Brake Antifreeze PNR5632



Penray

- Air brake antifreeze; Dryer & rust protector
- Provides complete winter protection
- protects entire air brake system from corrosion
- 32 fl. oz. / 12 per case
- Application: Use in gasoline & diesel vehicles

BLASTER

PENRAY

Chemicals

SHP



WE'VE GOT YOU COVERED!



Fuel & Oil System Maintenance • Power Steering Maintenance • Transmission Maintenance
• Lubricants, Penetrants & Coatings • Electrical System Maintenance • Tire Inflators • Brake Cleaners &
Maintenance • Professional Installer Kits • Diesel Fuel Treatments & Cleaners • Cold Weather Products
& Diesel Treatments Cooling System: Filters, Cleaners, Additives & Test Strips • Specialty Cleaners

FIND PRODUCT



Scan code above or go to
<http://bit.ly/PenDistributor>

Formulated for the professional technician, our full line covers your service needs bumper to bumper. 67 years strong, Penray provides products ensuring satisfied customers, higher profits and repeat business!

For more information contact your local distributor or visit penray.com

Ph. 800.373.6729



Fuel Supplements

Winter

PEAK Premium Windshield Deicer & Cleaner WAS30F6



Old World Ind.

- Premium winter season formula
- Deices light ice & frost
- Effective to -30°F
- 1 gal / 6 per case
- Application: Use in any vehicle

Fleet Charge 50/50 OLDFCA053



Old World Ind.

- Pre-Diluted fully formulated coolant
- Diesel specific coolant
- 50/50 mix of coolant & deionized water
- 1 gal / 6 per case
- Application: Use in heavy duty cooling systems

Winter Pow-R Plus Diesel Fuel Treatment PNR202032



Penray

- Prevents gelling of diesel fuel
- reduces cold filter plug point by as much as 30°F
- Improves cold weather starting
- 32 fl oz / 12 per case
- Application: Use in diesel fuel

Winter Thaw Emergency Diesel Fuel Treatment PNR202132



Penray

- Emergency diesel fuel treatment
- Dissolves gelled fuel fast
- Prevents ice crystal build-up in fuel lines
- Treats up to 25 gallons of fuel
- 32 fl oz / 12 per case
- Application: Use in diesel fuel

Diesel Fuel Supplement + Cetane Booster PWS1025



Power Service

- Prevents fuel gelling & protects against fuel-filter icing
- 32 oz / 12 per case
- Application: Effective in all diesel fuels

MOTOR MEDIC® De-Icer for Auto & Truck RADDE1



RSC

- Defrosts windshields, wipers and windows instantly
- Helps free frozen locks
- Spray in advance to prevent frost formation
- 12 oz / 12 per case
- Application: Use on windshields, wipers and windows

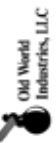

Chemicals

SHP

Parts Cleaners

Battery Cleaners

Battery Protector
PNR7011



Penray Companies

- Battery cleaner & protector
- Seals out moisture & prevents corrosive build-up; Orange tinted to guide user
- 11.5 wt. oz. / 12 per case
- Application: Use on batteries & battery terminals

Battery Cleaner
PNR7012



Penray Companies

- Neutralizes harmful battery acid and helps dissolve common deposits
- 15 oz. / 12 per case
- Application: Use on batteries & battery terminals

RD 90 Lubricant
PROCH-LU01



Pro-Par

- Stops battery corrosion
- Dries out wet ignition systems and motors
- Prevents rust / displaces moisture
- 11 oz. / 12 per case
- Application: Use on batteries & battery terminals

Battery Protector & Sealer
PTX80370



Permatex

- Seals and coats battery terminals eliminating the formation of acid salt corrosion
- Prevents terminal corrosion and battery drain
- 15 oz. / 12 per case
- Application: Use on batteries, battery terminals, and cables, in or out of storage

Electronic Cleaner Contact Cleaner
RADNM6



RSC

- Penetrates hard-to-reach areas to safely dissolve dust, grease, flux and other contaminants
- Evaporates quickly and completely
- 6 oz.
- Application: Use on electronic components, sensors, and electrical connectors



Chemicals

SHP

Parts Cleaners

Brake Cleaners

Brakleen Chlorinated
CRC05089



CRC Industries

- Original brake parts cleaner; chlorinated
- Removes grease, brake dust, brake fluids, oils, & other contaminants
- 19 wt. oz. / 12 per case
- Application: Use on brake parts, lining & pads

Brakleen Non-Chlorinated
CRC05088



CRC Industries

- Brake parts cleaner; non-chlorinated
- Removes grease, brake dust, brake fluids, oils, & other contaminants
- 14 wt. oz. / 12 per case
- Application: Use on brake parts, lining & pads

Brakleen Non-Chlorinated
CRC05050



CRC Industries

- Brake parts cleaner; non-chlorinated formula meets VOC regulations in all 50 states
- POWERJET technology provides a powerful, spray that blasts away contaminants
- 14 wt. oz. / 12 per case
- Application: Use on brake parts, lining & pads

Chlorinated Brake Parts Cleaner
PROCH-BC01



Pro-Par

- Cleans fast - dries fast
- Removes brake fluid, grease and oil
- Leaves no residue, non-flammable
- 18.5 oz. / 12 per case
- Application: Use on brake parts, lining & pads

Non-Chlorinated Brake Parts Cleaner
PROCH-BC02



Pro-Par

- Cleans fast - dries fast
- Removes brake fluid, grease and oil
- High pressure spraying
- 14 oz. / 12 per case
- Application: Use on brake parts, lining & pads

Non-Chlorinated, Hexane Free Brake Parts Cleaner
PROCH-BC03



Pro-Par

- 45% VOC
- Instant evaporation
- 14 oz. / 12 per case
- Application: Use on brake parts, lining & pads



Chemicals

SHP

Parts Cleaners

**Non-Chlorinated, Hexane Free
Brake Parts Cleaner
PROCH-BC04**



Pro-Par

- 10% VOC
- Fast evaporation
- CA/OTC VOC compliant
- 15 oz. / 12 per case
- Application: Use on brake parts, lining & pads

**Non-Chlorinated Brake & Parts Cleaner
PTX82220**



Permatex

- Non-chlorinated brake & parts cleaner
- Penetrates, dissolves & removes dirt & oil
- 20 wt. oz. / 12 per case
- Application: Use on brake systems, tools & C.V. joints; safe to use on aluminum

Brake Cleaners

**Non-Chlorinated Brake Cleaner
PNR4620**



Penray Companies

- Non-chlorinated brake cleaner & degreaser
- Low VOC formula; Dissolves & removes grease, oil brake fluid & other contaminants
- 14 wt. oz. / 12 per case
- Application: Use on brakes, C.V joints & clutch components

**GUNK® Brake Parts Cleaner Chlorinated
RADM720**



RSC

- Brake parts cleaner; chlorinated;
- Quickly dissolves & flushes brake dust, brake fluid, grease & oil contaminants
- Non-flammable
- 19 wt. oz. / 12 per case
- Application: Use on brake part components

**GUNK® Brake Parts Cleaner
Non-Chlorinated
RADM715**



RSC

- Brake parts cleaner; non-chlorinated;
- Cleans and degreases brake linings, cylinders, drums, rotors, clutches & CV joints
- Brake & CV joint cleaner; aerosol
- 14 wt. oz. / 12 per case
- Application: Use on brake part components



Chemicals

SHP

Parts Cleaners

Machinery Cleaners

Lectra-Motive Electric Parts Cleaner

CRC05018



CRC Industries

- Electric parts cleaner; non-flammable
- Dissolves grease, oil, dirt, & wax without having to remove parts
- 19 wt. oz. / 12 per case
- Application: Use on air tools, bearings, cables, solenoids & other electric parts

GUNK® Carburetor Parts Cleaner

RADM4814



RSC

- Carburetor parts cleaner; non-chlorinated
- Removes dirt, varnish, gum & sludge
- 12.5 wt. oz. / 12 per case
- Application: Use on carburetors & combustion chamber of gasoline engines

GUNK® Engine Degreaser

RADEB1



RSC

- Original engine degreaser; fast-acting
- Removes tough grease & oil build-up
- 15 wt. oz. / 12 per case
- Application: Use on engine & engine components

GUNK® Industrial Contact Cleaner

RADPD11CC



RSC

- Protects sensitive electronic components
- Penetrates hard-to-reach areas to safely dissolve dirt, grease & other contaminants
- 11 wt. oz. / 12 per case
- Application: Use on electrical components, connectors, contacts & electrical motors



Chemicals

SHP

Trailer & Truck Fluids

Antifreeze

Air Brake Antifreeze PNR5632



Penray

- Air brake antifreeze; Dryer & rust protector
- Provides complete winter protection
- protects entire air brake system from corrosion
- 32 fl. oz. / 12 per case
- Application: Use in gasoline & diesel vehicles

Pencool 3000 with Stabil-Aid Cooling System Treatment PNR300016



Penray

- Cooling system treatment with Stabil-Aid
- Helps prevent the formation of gel deposits in cooling systems & protects cooling system metals from corrosion
- 16 fl. oz. / 12 per case
- Application: Use in engine radiator

Application Chart

Antifreeze Protection (°F)

Cooling System Capacity ↓ Quarts	Quarts Antifreeze Required for Low-Temperature Protection →									
	3	4	5	6	7	8	9	10	11	12
9	5°	-15°	-43°	-76°						
10	10°	-4°	-26°	-54°	-76°					
11	12°	0°	-14°	-40°	-60°					
12	14°	5°	-8°	-28°	-51°					
13	15°	8°	0°	-14°	-44°	-61°	-76°			
14	17°	10°	3°	-8°	-28°	-44°	-60°			
15	18°	12°	5°	-4°	-14°	-35°	-54°	-76°		
16	19°	14°	9°	1°	-9°	-28°	-44°	-60°		
17	20°	16°	11°	3°	-2°	-15°	-31°	-60°		
18	21°	17°	12°	5°	0°	-13°	-26°	-33°	-53°	-76°
19		18°	13°	7°	2°	-10°	-20°	-32°	-50°	-60°
20			14°	9°	3°	-6°	-15°	-26°	-33°	-54°
21			15°	12°	5°	0°	-10°	-22°	-32°	-51°
22			16°	13°	8°	3°	-5°	-10°	-28°	-33°
23			17°	13°	10°	4°	-3°	-8°	-22°	-32°

Coolant's Basic Components:

Water

Water is an excellent heat transfer fluid, however freezes at low temperatures.

Glycol

Glycol is added to provide freeze and boil-over protection. It reduces the heat transfer capacity of water. It is usually mixed 50/50 with water.

Supplemental Coolant Additives

Nitrites are added to coolant to protect iron and steel components from cavitation, pitting and rust corrosion. Silicate is added to protect aluminum surfaces. Tolytriazole and Mercaptobenzothiazole are used to protect copper and brass metal. Phosphate or Borate are pH buffers used to control alkalinity.

Chemicals



SHP

Trailer & Truck Fluids

Antifreeze

Final Charge Global - Extended Life

Part Number	Size	
OLDFXA0B3	1 gal	Concentrate Bottle
OLDFXA0B1	55 gal	Concentrate Drum
OLDFXAB53	1 gal	50/50 Bottle

- Extended life coolant/antifreeze formula, red
- delivers total cooling system protection for 600,000 miles of on-road use
- 6 per case for the 1 gal size
- Application: Use in cooling systems of all types of heavy-duty diesel, gasoline & natural gas engines



(OLDFXA0B3)



(OLDFXA0B1)

Old World Ind.

Fleet Charge 50/50 OLDFCA053



- Pre-Diluted fully formulated coolant
- Diesel specific coolant
- 50/50 mix of coolant & deionized water
- 1 gal / 6 per case
- Application: Use in heavy duty cooling systems

Old World Ind.

Power Steering Fluid

Universal with Stop Leak RADM2732



- Stops leaks by conditioning seals
- Helps stop pump noise and wear
- 32 ft. oz.
- Application: Use on power steering system

RSC

Windshield Fluid

PEAK Bug Cleaner Wash OLDPBN0K3



- Peak bug wash with rain-off
- Premium summer formula
- 1 gal / 6 per case
- Application: Use to cut through: bugs, tree sap, baked on dirt & road grit

Old World Ind.

Peak Windshield Wash & Deicer WAS20F6



- Conventional blue all-season windshield cleaner
- Premix; -20°F
- Safe to use in any vehicle
- 6 per case for the 1 gal size
- Application: Use in any vehicle

Old World Ind.

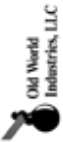

Chemicals

SHP

Trailer & Truck Fluids

Windshield Fluid
PEAK Premium Windshield
Deicer and Cleaner
WAS30F6



Old World Ind.

- Premium winter season formula
- Deices light ice & frost
- Effective to -30°F
- 1 gal / 6 per case
- Application: Use in any vehicle

Tech Tip

Signs of Wiper Blade Wear

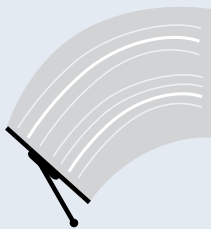

Streaking

Bands of water remain after stroke. Visual inspection will reveal rubber that has hardened and/or cracked due to exposure.

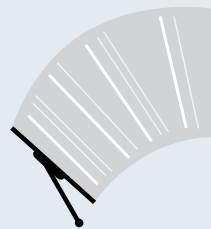

Chattering

Blades skip & vibrate over the windshield. Caused by exposure to extreme heat or cold temperatures or extended periods of non-use.

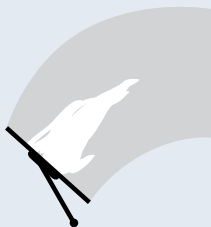

Smearing

Occurs when the wiping edge of the blade is no longer sharp. Wiper will smear the water across the windshield instead of cleaning it off.



Split Rubber

Age or physical damage to blades result in unwiped areas. A visual inspection will reveal any physical damage.

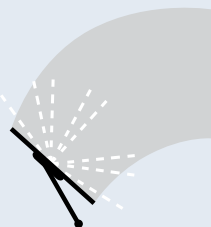

Squeaking

Old or worn rubber of the blade does not move quietly across the windshield.

See Wiper Blade Options on Page 682.

Chemicals
Old World Industries, LLC
SHP

Shop Supplies

Grease

5th Wheel

5th Wheel & Slider Lube LUC10030



Lucas Oil

- Clean, inexpensive alternative to grease for 5th wheels & sliders
- Virtually waterproof
- 1 pint / 12 per case
- Application: Use on 5th wheels & sliders

Inner Slide Lube PNR7005



Penray

- Contains high concentration of Moly Sulfide
- Increases slide & piston life on rails, fifth wheels & rollers; Clings to surfaces
- 10.5 oz / 12 per case
- Application: Use on fork lift inner slides, elevator slides, rails, torsion bars, fifth wheels & rollers

Slik-Pak 5th Wheel Grease PTX01010



Permatex

- Premeasured grease comes in handy pouch
- Requires no tools, creates no mess
- Effective at extreme temperatures & environmental conditions; Designed for heavy duty applications
- Application: Use on 5th wheels & forklift slides

Multi-Purpose

X-TRA Heavy Duty Grease

	Size
LUC10301-30	14.5 oz cartridge / 10 per case
LUC10330	1 lb tub / 12 per case

- Lasts up to 4 times longer than conventional lithium grease
- Fortified with an extreme pressure additive package
- Application: Use in heavy duty trucks & high speed bearings



(LUC10301-30)



(LUC10330)

Lucas Oil

LUCAS OIL

PENRAY

Permatex

Lubricants

SHP

Grease

5th Wheel

Lubriplate X-357 Lubricant
LUB-GRS005



Lubriplate

- Extreme pressure moly lubricant
- Water resistant & unaffected by temperature extremes; Penetrates & adheres
- 11 wt oz / 12 per case
- Application: Use on pintle hooks, slide axles, open gears & fifth wheels

Lubriplate 630 Series Lithium Grease
LUB-DSL002



Lubriplate

- Multi-purpose, lithium-based grease
- 14.5 oz cartridge / 10 per case
- Application: Use with automatic greasing systems

Special Auto Marine Grease
LUB-GRS012



Lubriplate

- Multi-purpose, high temp, extreme pressure grease
- Water repellent; Seals out dirt
- 14.5 oz cartridge / 10 per case
- Application: For automotive & marine uses

Liquid Wrench Trailer Bearing Grease
RADGR013



RSC

- Long lasting rust & corrosion protection
- Resists heat & washout
- Allows for high load carrying capacity
- 14 oz / 10 per case
- Application: Use on all trailer bearings & chassis lubrication points

Liquid Wrench Marine Grease
RADGR015



RSC

- Special water-insoluble formula
- Superior rust & corrosion protection
- 15 oz / 10 per case
- Application: Use in corrosive marine environments

Lubricants



SHP

Grease

Multi-Purpose

Dri-Slide Multi-Purpose Lubricant

	Size
LUB-DSL001	5.25 oz
LUB-DSL001-1	32 oz

- Multi-purpose lubricant; dry film formula; aerosol
- Resist salt, moisture & other corrosive elements
- Effective at extreme temperatures
- Stays in place once applied
- Application: Use on metal surfaces



(LUB-DSL001)



(LUB-DSL001-1)

Dri-Slide

Wheel End

Mobilith SHC 007 Grease LUB-GRS010



- NLGI 00 Grade / ISO VG 460 grease with a synthetic base fluid
- Excellent protection against wear, rust & corrosion
- 35 lb pail
- Application: Use in grease-filled industrial gear cases subject to high temps

Mobile

Delo HD Synthetic Grease SF LUB-GRS019



- Formulated to perform in unusually demanding conditions of high & low temps
- Excellent for demanding application requiring extended lubrication intervals
- 30 lb pail
- Application: Trailer wheel ends operating in a wide range of weather conditions

Chevron

Sta-Plex Extreme Pressure Premium Red Grease CRCSL3190



- Superior multi-purpose certified lithium complex based NLGI #2 grease
- extreme pressure, anti-wear, & anti-oxidation additives
- 14 oz / 10 per case
- Application: Ideal for high temperature & performance applications, bearings

CRC Industries

Liquid Wrench Extreme Pressure Red Grease RADGR016



- High film strength
- Contains anti-oxidants & corrosion inhibitors
- 14 oz / 10 per case
- Application: Ideal for use in high temps or extreme conditions

RSC



Lubricants

SHP

Grease

Wheel End

**Red 'N' Tacky
Red Lithium Grease
LUC10005-30**



Lucas Oil

- Smooth, tacky, red lithium 12-HO grease
- Fortifies with a high degree of extreme pressure additives; Water resistant
- 14 oz / 10 per case
- Application: Use in sliding surfaces & open gears

**Mystik Moly Grease
LUB-GRS007**



Citgo

- Premium lithium complex grease
- Industrial & heavy duty fleet grease with 1.5% moly (equiv. performance to 3% moly grease)
- 14 oz / 10 per case
- Application: Use with bearings, fifth wheels, king pins, slack adjusters, pins & bushings

**RPM Universal SAE 80W-90
Gear Lubricant
LUB-GEA001**



Chevron

- Premium grade, multi-purpose gear lubricant
- Protects against wear, seizure, oxidation, corrosion, rust & foam
- 32 fl oz / 12 per case
- Application: Use on truck axles & wheel hubs

**Lubriplate No. 105
Motor Assembly Grease
LUB-GRS004**



Lubriplate

- Smooth light-bodied grease made especially for motor assembly
- Protects machined engine parts from rust & corrosion; Prevents "Dry Start"
- 10 oz / 12 per case
- Application: Use on machined engine parts

**Extreme Pressure Lube #3
HENS-21337**



Hendrickson

- Anti-scoring, extreme pressure lube #3
- 4oz
- Application: Use with Hendrickson bushing tool

LUCAS OIL

HENDRICKSON

Lubricants

SHP

Lube

Food-Grade

Food-Grade Lube

	Size
TOD39000-1006	4 oz
TOD39000-1012	12 oz
TOD39000-1016	1 gal

- Food-grade quality lubricant
- Protects against wear, friction, corrosion & oxidation
- Compatible with rubber & other sealing materials
- Application: Use to lubricate springs, rollers, bearings, hinges & locks



(TOD39000-1016)



(TOD39000-1012)



(TOD39000-1006)

Todco

Hinge / Latch / Roller

OHD Hardware Lubricant

Size	
9.3 wt oz / 12 per case	PROOHLUBE-1
1 gal	PROOHLUBE-2



Pro-Par

- Formulated for Pro-Par overhead doors
- Dry, tack-free film resists dust & dirt
- Non-staining; Safe for most surfaces
- Application: Use on roll-up and swing door hardware

Liquid Wrench Lubricating Oil RADL212



RSC

- Stops squeaks & eases sticking parts
- Protects against rust
- 11 oz / 12 per case
- Application: Use on exterior locks, electronic appliances & small hinges

Liquid Wrench Silicone Spray RADM914



RSC

- Provides a slick coat of protection
- Repels water & inhibits rust; Extends life of metal & non-metal surfaces
- 11 oz / 12 per case
- Application: Use on rubber, plastic, wood & metal

Dry Graphite Lube PNR7009



Penray

- Lubricates & protects by penetrating into uneven microscopic surfaces
- Protects against rust & corrosion
- Excellent reducer of friction & heat
- 10 wt oz / 12 per case
- Application: Use on wood, metal, plastic, rubber, leather & painted surfaces



Lubricants

SHP

Lube

Hinge / Latch / Roller

White Lithium Grease
CRC05037



CRC Industries

- High quality, multi-purpose grease
- Protects against moisture & heat
- 10 wt oz / 12 per case
- Application: Use for metal-to-metal applications, hinges, latches, cams & cables

White Lithium Grease
PTX81981



Permatex

- All-purpose white lubricant
- Protects against rust & makes surfaces friction-free
- 10.75 oz / 12 per case
- Application: Use for metal-to-metal or metal-to-plastic applications, hinges & latches

Sta-Lube General Purpose Lithium Grease
LUB-GRS001



CRC Industries

- High purity, NLGI Grade 2 lithium based grease
- Designed for light duty applications requiring long grease life
- 14 oz / 10 per case
- Application: Use on hinges, latches, OHD tracks, chains & cables

Liquid Wrench White Lithium Grease

	Size
RADL616	10.25 oz / 6 per case
RADL666	16 oz tub / 12 per case

- Creates long-lasting, heavy duty lubrication
- Provides a thick grease coat
- Does not freeze, melt or run
- 10.25 oz / 6 per case
- Application: Use on large outdoor hinges



(RADL616)



(RADL666)

RSC



Lubricants

SHP

Lube

Penetrating

Multi-Purpose Power Lube CRC05005



CRC Industries

- Fast acting multi-purpose lubricant
- All in one product quickly penetrates, lubricates, stops squeaks, fights corrosion & loosens rusted parts; Non-staining
- 9 wt oz / 12 per case
- Application: Use on hinges, door locks, wheels & lug nuts

PB Penetrating Catalyst PBB16-PB



PB Blaster

- Quickly breaks loose surface tension rust & corrosion by creeping up, around & in to hard-to-reach cavities
- Loosens rusty nuts & bolts
- 11 oz / 12 per case
- Application: Use on brake, exhaust & suspension system jobs

Heavy Duty Penetrant Lubricant PROCH-LU02



Pro-Par

- Cleans and protects faster
- Rust inhibitor and moisture displacer
- Non-conducting up to 45,000 volts
- 20 oz. / 12 per case
- Application: Use to loosen nuts and bolts

Fast Break Super Penetrant PTX80052



Permatex

- Penetrate & loosens rust, tar, grease, dirt, carbon deposits & corrosion from metal parts
- For rusted & frozen assemblies
- 12 wt oz / 12 per case
- Application: Use on frozen nuts, bolts & fittings in all types of assemblies

Anti-Seize Lubricant

Size	
8.5 oz	PTX81464
8 fl. oz.	PTX80078



Permatex

- Highly refined blend of aluminum, copper and graphite lubricants
- Use during assembly to prevent galling, corrosion and seizing due to weathering or chemicals
- 8.5 oz
- Application: Use on spark plugs, cylinder head and exhaust head bolts

Liquid Wrench Penetrating Oil RADL112



RSC

- Frees stuck nuts, bolts & locks; Quickly penetrates corrosion
- Dissolves rust & cuts through grease
- 11 oz / 12 per case
- Application: Use on frozen nuts, bolts, clamps, pipes & frozen mechanisms



SHP

Lubricants

Lube

Tool

ATC Air Tool Conditioner
PBB16-ATC



PB Blaster

- Designed to restore & prolong air tool life by cleaning, coating & lubricating tools
- Breaks loose deposits that accumulate over time; Lubricant formulation inhibits rust
- 12 oz / 12 per case
- Application: Use on air tools

Professional Air Tool Lubricant
PBB16-ATL



PB Blaster

- Lubricates and protects internal tool parts
- Ensures maximum tool performance, prevents unnecessary maintenance
- 16 fl. oz.
- Application: Use on air tools

Gun Oil
LUC10006



Lucas Oil

- Developed to prevent jamming & over-heating
- Stands up to high combustion temperatures
- Protects against moisture & is completely odorless
- 2 oz / 18 per case
- Application: Use to protect against rust and moisture

Heavy Duty Air Tool Lubricant
LUC10216



Lucas Oil

- Superior lubricant; Extends tool life
- Combats rust & varnish
- Coats the working parts with a cushion of waterproof lubricants that resists blowout
- 1 pt / 12 per case
- Application: Use on air tools

BLASTER
LUCAS OIL
Lubricants

SHP

Terminology

Viscosity

Engine Oil	Viscosity	Similar To
SAE 10	50 to 100	Corn Oil
SAE 30	150 to 200	Maple Syrup

Engine Oil	Viscosity	Similar To
SAE 40	250 to 500	Castor Oil
SAE 60	1,000 to 2,000	Glycerin

Shop Supplies

Oil

Gear

SAE 75W-90 Synthetic Gear Oil

	Size
LUC10047	1 qt
LUC10048	1 gal

- Non-foaming, super slick, long lasting lubricant designed for heavy duty or high performance application
- Cushions gears & resists "squeezing out" under extreme pressure
- 1 qt / 12 per case
- Application: Use on gears, transmissions & differentials



(LUC10047)



(LUC10048)

Lucas Oil

Heavy Duty 80W-90 Gear Oil

	Size
LUC10043	1 qt
LUC10046	1 gal

- Fortified with special anti-wear agents & lubricity agents to control wear & drag along with additives to control heat
- Excellent for heavy-duty applications
- Application: Provides the ultimate protection to gear components



(LUC10043)



(LUC10046)

Lucas Oil

RPM Universal SAE 80W-90 Gear Lubricant LUBUN8090



- Premium grade, multi-purpose gear lubricant
- Protects against wear, seizure, oxidation, corrosion, rust & foam
- 32 fl oz / 12 per case
- Application: Use on truck axles & wheel hubs

Chevron

LUCAS OIL

Lubricants

SHP

Oil

Gear

**API/GL-5 Plus New Generation
85W-140 HD Limited Slip Gear Oil
CRCSL2432**



CRC Industries

- Extreme pressure, multi-purpose gear oil
- Meets SAE specs
- 32 fl oz / 12 per case
- Application: For complete fill or topping off of manual transmissions or differentials operating under high speed, low torque; and low speed, high torque conditions

**Heavy Duty
85W-140 Gear Oil
LUC10042**



Lucas Oil

- excellent for heavy-duty applications
- Fortified with special anti-wear agents & lubricity agents to control wear & drag along with additives to control heat
- 1 qt / 12 per case
- Application: Use on gears; Ideal for older gear boxes

Hub

	Size
LUC10088	32 oz
LUC10089	5 gal

- Allows hubs to run on a marginal amount of oil in case of a blown seal or poor maintenance
- Excellent gear lube for heavy-duty applications
- Application: Use to stop leaks in steering axles & trailer hubs on heavy duty trucks



(LUC10088)



(LUC10089)

Lucas Oil



Lubricants

SHP

Oil

Supplements

Power Steering Stop Leak

	Size
LUC10011	1 qt (12 per case)
LUC10008	12 oz (12 per case)

- Stop seal leaks in power steering units
- Effective in reducing slack, squeals, & hard spots in worn rack & pinions
- Immediate & long lasting
- Application: Use in power steering reservoir to stop leaks



Lucas Oil

Heavy Duty Oil Stabilizer

	Size
LUC10001	1 qt (12 per case)
LUC10002	1 gal (4 per case)

- Increases oil life by 50%
- Pure petroleum multi-use oil supplement
- Eliminates dry starts and reduce friction, heat & wear in any type of engine
- Application: Use in gear oil to stop leaks, reduce operating temperatures & increase the life of the gear oil



Lucas Oil

LUCAS OIL

Lubricants

SHP

Application Chart

Gear Oil Viscosity

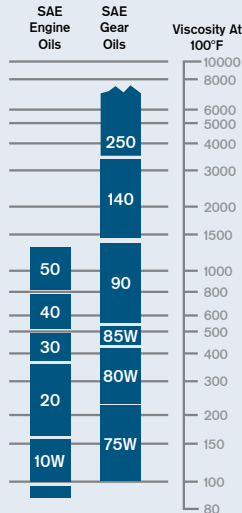

Substitutions

Gear oil ratings are not directly comparable with engine oil. If it is necessary to mix brands of oil, use the same viscosity grade to maintain performance.

API Symbol

Look for the API symbol on oil products for viscosity grade.

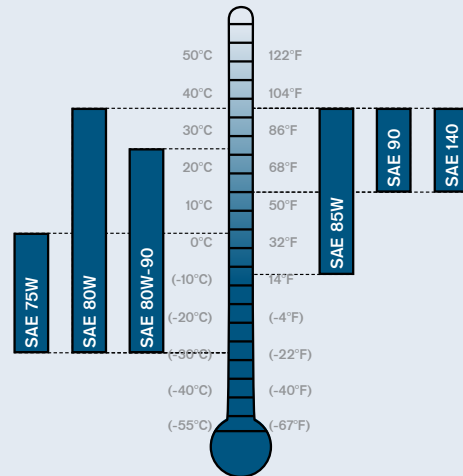
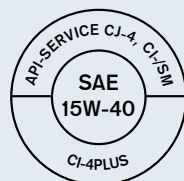

Coatings

Instant Cold Galvanize Coating CRC05048



CRC Industries

- High performance coating of 95% pure zinc that electrochemically bonds to ferrous metals
- Provides protection like hot dip galvanize
- 13 wt oz / 12 per case
- Application: Use on fasteners, welds & doors

Cold Galvanize Primer PNT1-1



Pro-Par

- Dried paint film with over 93% zinc
- Excellent adherence to galvanized surfaces exposed to the severest corrosive conditions
- 16 wt oz / 12 per case
- Application: Use on fasteners, welds & doors

Paints

1 Gallon Paint / Enamel

Part Number	Color
PNT3-14	Black Gloss
PNT7-17	Gray Enamel
PNT11-13	Red #89
PNT13-10	White Enamel
PNT13-12	Reefer White

- High Solids, one coat coverage
- Protects against corrosive chemicals
- Resists abrasion & heat
- Lead-free; Sag-resistant
- Application: Protects equipment from exposure to the elements & chemicals



Pro-Par

Big Rig Professional Coatings PNT11-23



Seymour

- Superior high solids fleet maintenance paint formulated for maximum performance
- Prevents rust & resists oil, gas, abrasion & heat
- Bright fleet red
- 16 wt oz / 6 per case

Spray Paints O.E. Shiny Galvanized PNT11-5



Seymour

- Shiny galvanized coating that protects & matches new galvanized metal
- Resists oxidation & eliminates the need for an aluminum topcoat
- 13 wt oz / 6 per case



Paints

SHP

Paints

Spray Paints

Stainless Steel PNT12-3



Seymour

- Formulation containing 316L stainless steel pigment to provide maximum corrosion resistance & protection against weather, sunlight, oil, & water
- Dries to a satin finish
- Recommended as a topcoat
- 16 wt oz / 6 per case

Pro-Par 16 oz. Spray Paint

Part Number	Color
PNT3-1	Black Gloss
PNT3-20	Flat Black
PNT9-6	JB Hunt Orange
PNT11-26	Swift Red
PNT11-27	Royal Blue
PNT11-28	Federal Gray
PNT11-29	Dull Aluminum
PNT13-11	Reefer White
PNT13-22	White Gloss



- High solids coverage
- Abrasion & chemical resistant
- Outdoor durability
- 16 oz / 12 per case

Pro-Par

MRO Industrial Enamel 16 oz. Spray Paint

Part Number	Color
PNT4-11	Deep Blue
PNT7-32	Machinery Gray Gloss
PNT7-34	Light Machinery Gray
PNT11-20	Safety Red
PNT11-30	Safety Yellow Gloss
PNT11-33	Safety Orange
PNT14-10	Caterpillar Yellow
PNT620-1449	Dark Green



- Formulated for maximum performance
- High solids paint does not run or sag
- Can be applied to bare metal
- Resists oil, gas, heat, and sunlight
- 16 oz / 6 per case

Seymour

SEYMOUR
"The Inventor of Aerosol Spray Paint"

pro-par
16 oz. Aerosol Spray Paints

Paints

SHP

Primers

Pro-Par

Part Number	Type	Size	Color
PNT11-22	Spray	20 oz / 17 oz fill	Red Oxide
PNT7-30	Spray	20 oz / 17 oz fill	Big Red Gray
PNT7-19	Gallon	1 gal	Gray

- High solids coverage
- Abrasion & chemical resistant; Outdoor durability
- Creates a waterseal between paint & material
- Application: Use primer before painting to create a totally flat surface; Wood is the most common surface for paint primers



(PNT11-22)



(PNT7-30)

Pro-Par

Rust Converter & Primer PNT1-2



Pro-Par

- Any iron or steel surface restored to a like new appearance
- 16 wt oz / 12 per case
- Application: Use on cars, trucks, trailers, railings, furniture & tools

Primer PNT3-21



- Flat Black
- 12 wt oz / 12 per case
- Application: Use on cars, trucks & trailers

Reducers & Removers

Decal & Sticker Remover PBB16-DSR



PB B'blaster

- Citrus-based solvent that quickly & easily removes adhesives & sticky films, as well as grease oils, & waxes
- Biodegradable; All-Purpose
- Leaves no residue
- 11 wt oz / 12 per case

Decal & Paint Stripper PTX80577



Permatex

- Quickly strips & removes decals, stickers, stripes & paint from bumpers, auto & truck bodies
- Eliminates sanding & scraping
- Works in 10-15 minutes
- 12 wt oz / 12 per case

Paints

SHP

Reducers & Removers

Graffiti Remover PNT20-047



Seymour

- Highly effective, environmentally safe formula that removes paint from brick, stucco, siding, concrete, & metal
- Safely removes paint & varnish
- Gel-like remover adheres to vertical surfaces
- 13 wt oz / 12 per case

Undercoats

Rubberized Spray Undercoating CRC5347



CRC

- Provides a tough, flexible shield against moisture, salt and road debris
- Dries quickly and is exceptionally resistant to adrasion
- 16 wt oz

Undercoats

Undercoating MMM0881



3M

- Provides a tough barrier and protects metal from road debris
- Hides welding marks and other repairs
- 16 wt oz / 6 per case

Plasti-Kote Undercoat PNT3-15



Pro-Par

- Flexible, rubberized, non-asphaltic coating
- effective sound barrier to reduce road noise
- protection against rust, corrosion, moisture, fumes, dust, heat & cold
- Black
- 12 wt oz / 12 per case

Rubberized Undercoat PNR4424



Penray

- Rustproofs, seals & protects
- Sprays on evenly, dries quickly & stays black & can be painted
- Rubber compound for flexibility
- 17 wt oz / 12 per case

Heavy Duty Rubberized Undercoating PTX81833



Permatex

- Excellent professional blend all-purpose coating
- Rubberized for maximum durability
- Seals, protects & insulates
- Rubber compound for flexibility
- 16 wt oz / 12 per case



Paints

Bolts

Base Rail

Length	1/4 in. - 20	5/16 in. - 18	3/8 in. - 16
1 in.	BLT-CB0410	BLT-CB0510	BLT-CB0610
1-1/4 in.	BLT-CB0411	BLT-CB0511	BLT-CB0611
1-1/2 in.	BLT-CB0412	BLT-CB0512	BLT-CB0612
2 in.	BLT-CB0420	BLT-CB0520	BLT-CB0620
2-1/2 in.	BLT-CB0422	BLT-CB0522	BLT-CB0622
3 in.	BLT-CB0430	BLT-CB0530	BLT-CB0630

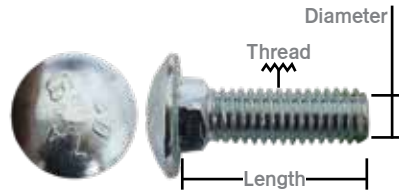

Pro-Par

	Grade	Diameter	Thread	Length	Material	Head
BLT00233	302	3/8 in.	16	1-1/4 in.	Stainless Steel	Button
SCW60750210	302	3/8 in.	16	1 in.	Stainless Steel	Button
BLT2-13		5/16 in.	18	1 in.	Stainless Steel	Round
BLT60753117	5	3/8 in.	16	1-1/2 in.	Steel	Button
BLT60753101	5	3/8 in.	16	1-7/8 in.	Steel	Truss
BLTF8721668-96		3/8 in.	16	1 in.		Torx
BLTF8721689-96		3/8 in.	16	1-1/4 in.		Torx



Crossmember Bolt Kit BLT60759950



Item	Count	Diameter	Thread	Length	Material
Bolts	8	3/8 in.	16	1-1/4 in.	
Washers	8				Nylon
Nuts	8	3/8 in.	16		

Crossmember Bolt Kit BLT60759920



Item	Count	Diameter	Thread	Length	Material
Bolts	8	3/8 in.	24	1-1/4 in.	
Washers	8				Nylon
Nuts	8	3/8 in.	24		

Base Rail Bolt Kit BLT16-20



NOTE: Each kit contains (8) bolts and (8) nuts.
Sell pack is 65 kits.

Item	Count	Grade	Diameter	Thread	Length
Bolts	8	5	3/8 in.	16	1-1/4 in.
Flange Nuts	8	5	3/8 in.	16	

Container Bolt Kit BLTKIT1207



Item	Count	Grade	Diameter	Thread	Length
Bolts	22	5	3/8 in.	16	1 in.
Washers	22		25/64 in.		21/32 in.
Hex Nuts	22		3/8 in.	16	

Fasteners

SHP

Bolts

Base Rail

Base Rail Bolt Kit SIRBRBK



Item	Count	Diameter	Thread	Length
Bolts	8	3	16	1-1/4 in.
Flange Nuts	8			

Carriage

Rib-Neck

Length	1/4 in. - 20	5/16 in. - 18	3/8 in. - 16
1-1/4 in.	BLT-CBRN0411	BLT-CBRN0511	BLT-CBRN0611
1-1/2 in.	BLT-CBRN0412	BLT-CBRN0512	BLT-CBRN0612
2 in.	BLT-CBRN0420	BLT-CBRN0520	BLT-CBRN0620

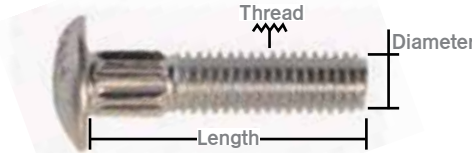

Pro-Par

Step

Length	1/4 in. - 20	5/16 in. - 18	3/8 in. - 16
1-1/4 in.	BLT-CBST0411	BLT-CBST0511	
1-1/2 in.	BLT-CBST0412	BLT-CBST0512	BLT-CBST0612
2 in.	BLT-CBST0420		BLT-CBST0620

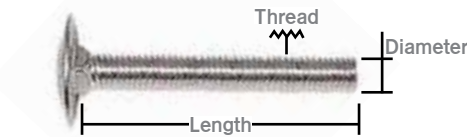

Pro-Par

	Grade	Diameter	Thread	Length	Material	Neck	Head
BLT11-20	5	3/8 in.	16	1-1/2 in.	Steel	Ribbed	Round
BLT11-30	5	3/8 in.	16	1-1/2 in.	Steel	Square	Round
BLT11-201	5	3/8 in.	16	1-3/4 in.	Steel	Ribbed	Round
BLT11-230	18-8	5/16 in.	18	3/4 in.	Stainless Steel	Square	Round
BLT11-232		1/4 in.	20	1-1/4 in.		Ribbed	Round

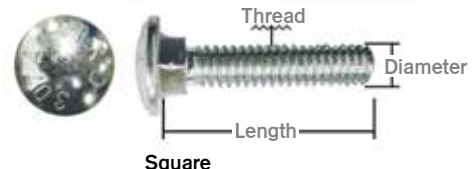
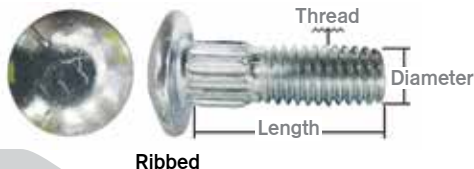

Fasteners

SHP

Bolts

Length	1/4 in. - 20	5/16 in. - 18	3/8 in. - 16	Elevator
1-1/4 in.	BLT-CBEL0411	BLT-CBEL0511	BLT-CBEL0611	
1-1/2 in.	BLT-CBEL0412	BLT-CBEL0512	BLT-CBEL0612	
1-3/4 in.	BLT-CBEL0413		BLT-CBEL0613	
2 in.	BLT-CBEL0420	BLT-CBEL0520	BLT-CBEL0620	
2-1/2 in.	BLT-CBEL0422		BLT-CBEL0622	
3 in.	BLT-CBEL0430		BLT-CBEL0630	

Elevator Bolt Assy. Kits

BLTMDRBOLT14114

Item	Count	Diameter	Thread	Length
Bolts	100	1/4 in.	20	1-1/4 in.
Kep Nuts	100	1/4 in.		

TMB700-50-7

Item	Count	Diameter	Thread	Length
Bolts	100	1/4 in.	20	1-1/2 in.
Kep Nuts	100	1/4 in.		



Pro-Par

FRP

	Type	Diameter	Thread	Length	Color
BLT12-1	Corroflo	3/8 in.	16	1 in.	Steel
BLT12-2	Corroflo	3/8 in.	16	1-1/4 in.	Steel
BLT6-2	Standard	5/16 in.	18	7/8 in.	Zinc
BLT6-3	Standard	5/16 in.	18	1 in.	Zinc
BLT99-3	Torx	1/4 in.	20	7/16 in.	Zinc
SCW60753087	Torx	5/16 in.	18	1-3/8 in.	Steel
BLT99-2	Torx	5/16 in.	18	5/8 in.	
MOR051049	Torx				
MOR051051	Torx				
BLTF6719580-63007C	Encapsulated	5/16 in.	18	7/8 in.	Gray
BLT9-5	Encapsulated	5/16 in.	18	1 in.	Gray
BLT9-6	Encapsulated	5/16 in.	18	1 in.	White
BLT9-7	Encapsulated	5/16 in.	18	1-1/4 in.	Gray
BLT9-9	Encapsulated	3/8 in.	16	1-7/8 in.	Gray



Bolts

FRP

Anti-Theft DuraPlate® Rear Door Kit

BLTKIT-3

Gray ribbed neck FRP

Item	Count	Grade	Diameter	Thread	Length
Bolts	28	5	5/16 in.	18	1 in.
Bolts	88	5	5/16 in.	18	7/8 in.
Bolts	2	5	5/16 in.	18	1-1/4 in.
Cam Tee-Nuts	48	-	5/16 in.	18	3/16 in.
Tee-Nuts	2	5	5/16 in.	18	1/2 in.



Hex Head

SAE- Yellow Plated, Grade 8

Length	5/8 in. - 18	3/4 in. - 16	7/8 in. - 14
1 in.	BLT-GES1010	BLT-GES1210	
2-1/2 in.	BLT-GES1022	BLT-GES1222	BLT-GES1422*
5 in.	BLT-GES1050	BLT-GES1250	BLT-GES1450*

*Plain

Pro-Par

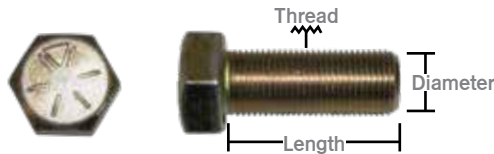

USS- Yellow Plated, Grade 8

Length	1/4 in. - 28	5/16 in. - 18	3/8 in. - 16	7/16 in. - 20
3/4 in.	BLT-GEU0403	BLT-GEU0503	BLT-GEU0603	BLT-GEU0703
1 in.	BLT-GEU0410	BLT-GEU0510	BLT-GEU0610	BLT-GEU0710
1-1/4 in.	BLT-GEU0411	BLT-GEU0511	BLT-GEU0611	BLT-GEU0711
1-1/2 in.	BLT-GEU0412	BLT-GEU0512	BLT-GEU0612	BLT-GEU0712
2-1/2 in.	BLT-GEU0422	BLT-GEU0522	BLT-GEU0622	BLT-GEU0722
3 in.	BLT-GEU0430	BLT-GEU0530	BLT-GEU0630	BLT-GEU0730
Length	1/2 in. - 13	5/8 in. - 11	3/4 in. - 10	
1 in.	BLT-GEU0810	BLT-GEU1010	BLT-GEU1210	
1-1/4 in.	BLT-GEU0811	BLT-GEU1011	BLT-GEU1211	
1-1/2 in.	BLT-GEU0812	BLT-GEU1012	BLT-GEU1212	
1-3/4 in.	BLT-GEU0813	BLT-GEU1013	BLT-GEU1213	
2 in.	BLT-GEU0820	BLT-GEU1020	BLT-GEU1220	
2-1/2 in.	BLT-GEU0822	BLT-GEU1022	BLT-GEU1222	
3 in.	BLT-GEU0830	BLT-GEU1030	BLT-GEU1230	
3-1/2 in.	BLT-GEU0832	BLT-GEU1032	BLT-GEU1232	
4 in.	BLT-GEU0840	BLT-GEU1040	BLT-GEU1240	
4-1/2 in.	BLT-GEU0842	BLT-GEU1042	BLT-GEU1242	

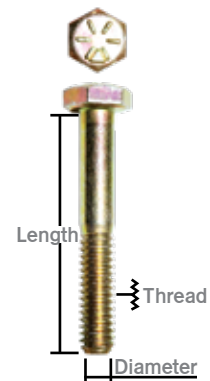

Pro-Par

pro-par
Genuine Pro-Par Parts

Fasteners

SHP

Bolts

Hex Head

USS Flange, Grade 8

Length	1/2 in. - 13	5/8 in. - 11	3/4 in. - 10
1-3/4 in.	BLT-GEUF0813	BLT-GEUF1013	
2 in.	BLT-GEUF0820	BLT-GEUF1020	BLT-GEUF1220
2-1/4 in.	BLT-GEUF0821	BLT-GEUF1021	

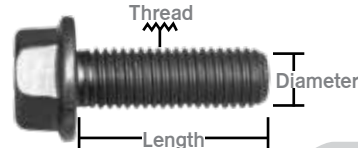

Pro-Par

USS- Zinc Plated, Grade 5

Length	1/4 in. - 20	5/16 in. - 18	3/8 in. - 16	7/16 in. - 14
3/4 in.	BLT-GFU0403	BLT-GFU0503	BLT-GFU0603	BLT-GFU0703
1 in.	BLT-GFU0410	BLT-GFU0510	BLT-GFU0610	BLT-GFU0710
1-1/4 in.	BLT-GFU0411	BLT-GFU0511	BLT-GFU0611	BLT-GFU0711
1-1/2 in.	BLT-GFU0412	BLT-GFU0512	BLT-GFU0612	BLT-GFU0712
1-3/4 in.	BLT-GFU0413	BLT-GFU0513	BLT-GFU0613	BLT-GFU0713
2 in.	BLT-GFU0420	BLT-GFU0520	BLT-GFU0620	BLT-GFU0720
2-1/2 in.	BLT-GFU0422	BLT-GFU0522	BLT-GFU0622	BLT-GFU0722
3 in.	BLT-GFU0430	BLT-GFU0530	BLT-GFU0630	BLT-GFU0730

Length	1/2 in. - 13	5/8 in. - 11
1-1/4 in.	BLT-GFU0811	BLT-GFU1011
1-1/2 in.	BLT-GFU0812	BLT-GFU1012
2 in.	BLT-GFU0820	BLT-GFU1020
2-1/2 in.	BLT-GFU0822	BLT-GFU1022



Pro-Par

Specialty

	Grade	Diameter	Thread	Length	Material
BLT60753008	2	5/16 in.	18	1 in.	Steel
BLT1-250	5	1/4 in.	20	2-1/2 in.	Steel
BLT1-302	5	1/2 in.	13	4-1/2 in.	Steel
BLT1-381A	5	5/8 in.	18	5-1/4 in.	Steel
MOR051047		1/4 in.	20	5/16 in.	

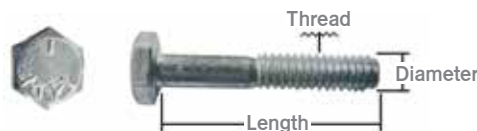

Fasteners



SHP

Bolts

Specialty Kits

Flap Mounting Bolt Kit

Part Number	Count
BESB516P	Single Kit
IMXGT-27516B	Single Kit
IMXGT-27516BUCKET	50 Kits

- Kit Includes: 4 Bolts, 4 Lock Washers, 4 Nuts & 8 Flat Washers



(BESB516P)



(IMXGT-27516BUCKET)

Landing Gear Bolt Kit BLT60759910



Item	Count	Diameter	Thread	Length
Bolts	10	5/8 in.	18	1-1/2 in.
Lock Nuts	10	5/8 in.		

Landing Gear Bolt Kit BLTFSP005-05KIT



Item	Count	Grade	Diameter	Thread	Length
Bolts	12	8	5/8 in.	18	1-7/8 in.
Lock Nuts	12	8	5/8 in.		
Flat Washers	12		5/8 in.		

TempBolt® Hubcap Bolt

Count	Part Number
Single	IMXGT-7600BULK
Kit of 4	WAB10900628K



(IMXGT-7600BULK)



(WAB10900628K)

- Provides a visual indicator that lets you know at a glance if a hub has reached 250°

More Information

www.MyAuroraPlus.com

Need more information on a particular trailer? Log into www.MyAuroraPlus.com for Aurora's Graphical Bill of Material (GBOM). Easily point and click through visual elements of a trailer to drill down to an individual trailer component.

Nuts

Anti Theft

	Type	Diameter	Thread	Material
NUT15-1	Anti Theft	3/8 in.	16	Zinc Plated/ Steel
NUT60752149	Tamper Proof Nut	1/2 in.	13	Steel

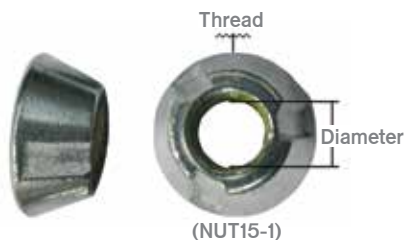

Anti-Theft Nut Socket TOL1-1



- To remove & install anti-theft NUT15-1

Finished Hex

Diameter	Thread	USS (Coarse), Grade 5	USS (Coarse), Grade 8
1/4 in.	20	NUT-HNU04	NUT-HNU804
5/16 in.	18	NUT-HNU05	NUT-HNU805
3/8 in.	16	NUT-HNU06	NUT-HNU806
7/16 in.	14	NUT-HNU07	NUT-HNU807
1/2 in.	13	NUT-HNU08	NUT-HNU808
5/8 in.	11	NUT-HNU10	NUT-HNU810



Pro-Par

Nylon Insert Lock

Diameter	Thread	USS (Coarse), Grade 2	USS (Coarse), Grade 8	Thread	SAE (Fine), Grade 8
1/4 in.	20	NUT-HNUNY04	NUT-HNUNY804	28	NUT-HNSNY804
5/16 in.	18	NUT-HNUNY05	NUT-HNUNY805	24	NUT-HNSNY805
3/8 in.	16	NUT-HNUNY06	NUT-HNUNY806	24	NUT-HNSNY806
7/16 in.	14	NUT-HNUNY07	NUT-HNUNY807	20	NUT-HNSNY807
1/2 in.	13	NUT-HNUNY08	NUT-HNUNY808	20	NUT-HNSNY808
9/16 in.	12	NUT-HNUNY09	NUT-HNUNY809	18	NUT-HNSNY809
5/8 in.	11	NUT-HNUNY10	NUT-HNUNY810	18	NUT-HNSNY810
3/4 in.	10	NUT-HNUNY12	NUT-HNUNY812	16	NUT-HNSNY812



Pro-Par

SHP

Nuts

"KEP" Lock

USS (Coarse), Grade 5

Grade	Diameter	Thread	
5	1/4 in.	20	NUT-HNKU04
5	3/8 in.	16	NUT-HNKU06

Pro-Par



Serrated Hex Flange Lock

USS (Coarse), Grade 5

Grade	Diameter	Thread	
5	1/4 in.	20	NUT-HNUF04
5	5/16 in.	18	NUT-HNUF05
5	3/8 in.	16	NUT-HNUF06

Pro-Par



Stover Lock

Diameter	Thread	USS (Coarse), Grade 8	Thread	SAE (Fine), Grade 8
1/4 in.	20	NUT-HNUST04	28	NUT-HNSST04
5/16 in.	18	NUT-HNUST05	24	NUT-HNSST05
3/8 in.	16	NUT-HNUST06	24	NUT-HNSST06
1/2 in.	13	NUT-HNUST08	20	NUT-HNSST08
9/16 in.	12	NUT-HNUST09	18	NUT-HNSST09
5/8 in.	11	NUT-HNUST10	18	NUT-HNSST10
3/4 in.	10	NUT-HNUST12	16	NUT-HNSST12
7/8 in.	9	NUT-HNUST14	14	NUT-HNSST14
1 in.	8	NUT-HNUST16	14	NUT-HNSST16



Pro-Par

Stover Flange Lock

SAE (Fine), Grade 5

Grade	Diameter	Thread	
GT	1/2 in.	13	NUT-HNSF08
GT	5/8 in.	11	NUT-HNSF10
GT	3/4 in.	10	NUT-HNSF12

Pro-Par



Fasteners

SHP

Nuts

Specialty

	Type	Grade	Diameter	Thread	Material
HOLXB-HNH-34-F	Lock	-	3/4 in.	16	-
NUT00236	Lock	-	1/2 in.	13	-
NUT2-20	Stover	5	3/8 in.	16	Zinc
NUT6-5	Jam	2	1 in.	14	Zinc Plated / Steel
HYU10015370	Jam				
FLT992-01100	Keep	-	1/4 in.	20 in.	Zinc

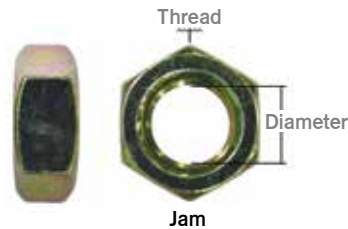

Tee

	Type	Diameter	Thread	Length	Color
NUT890-58000	Cam	5/16 in.	18	3/16 in.	Steel
NUT9-4	FRP	5/16 in.	18	3/8 in.	Steel
NUT9-5	FRP	5/16 in.	18	1/2 in.	Steel
NUT9-8	FRP	5/16 in.	18	5/8 in.	Steel
NUT449219420-07	Tee	5/16 in.	18	9/16 in.	Gray
NUT99-SPD	Tee	1/4 in.	20	7/16 in.	White
MOR052021	Tee	-	20	17/40 in.	Gray
NUT60750088	Tee	5/16 in.	18	1/2 in.	White
NUT60752011	Tee	5/16 in.	18	9/16 in.	White
WABNUT00203	Tee	5/16 in.	18	9/16 in.	White

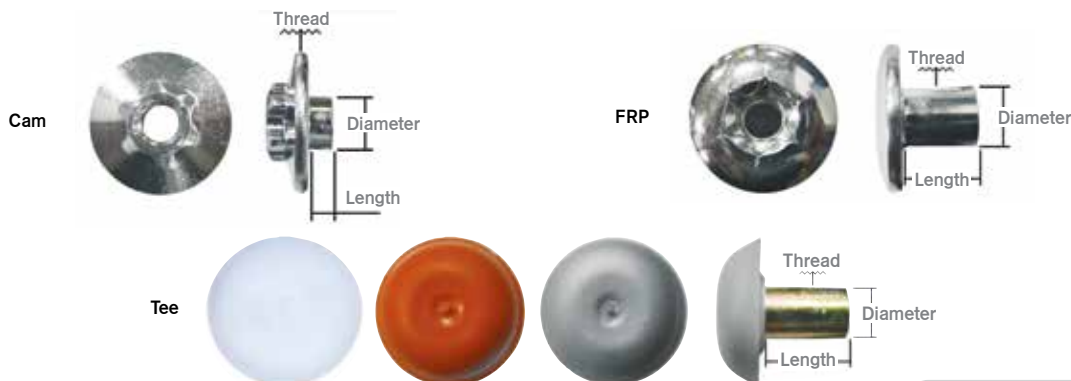

Pins

Steel Cotter

Length	1/8 in.	1/4 in.	3/8 in.
1 in.	PIN-CP2010	PIN-CP4010	
1-1/4 in.	PIN-CP2011		
1-1/2 in.	PIN-CP2012	PIN-CP4012	PIN-CP6012
1-3/4 in.	PIN-CP2013		
2 in.	PIN-CP2020	PIN-CP4020	PIN-CP6020
2-1/2 in.	PIN-CP2022	PIN-CP4022	



Pro-Par

Specialty

	Type	Length	Diameter
FRUAXA0409-PK1	Pro-Par Axle	1-1/4 in.	3/16 in.
HUKMGPB-R8-10G	Huck Pin	1-15/16 in.	1/4 in.

Conversion Chart

Fraction to Decimal

Fraction	Decimal (inches)	Decimal (metric)
1/64	0.0156	0.396
1/32	0.0313	0.795
3/64	0.0469	1.19
1/16	0.0625	1.587
5/64	0.0781	1.984
3/32	0.0938	2.383
7/64	0.1094	2.779
1/8	0.125	3.175
9/64	0.1406	3.571
5/32	0.1563	3.97
11/64	0.1719	4.366
3/16	0.1875	4.763
13/64	0.2031	5.159
7/32	0.2188	5.558
15/64	0.2344	5.954
1/4	0.25	6.35
17/64	0.2656	6.746
9/32	0.2813	7.145
19/64	0.2969	7.54
5/16	0.3125	7.937
21/64	0.3281	8.334
11/32	0.3438	8.733

Fraction	Decimal (inches)	Decimal (metric)
23/64	0.3594	9.129
3/8	0.375	9.525
25/64	0.3906	9.921
13/32	0.4063	10.32
27/64	0.4219	10.716
7/16	0.4375	11.112
29/64	0.4531	11.509
15/32	0.4688	11.908
31/64	0.4844	12.304
1/2	0.5	12.7
33/64	0.5156	13.096
17/32	0.5313	13.495
35/64	0.5469	13.891
9/16	0.5625	14.287
37/64	0.5781	14.684
19/32	0.5938	15.083
39/64	0.6094	15.479
5/8	0.625	15.875
41/64	0.6406	16.271
21/32	0.6563	16.67
43/64	0.6719	17.066
11/16	0.6875	17.462

Fraction	Decimal (inches)	Decimal (metric)
45/64	0.7031	17.859
23/32	0.7188	18.258
47/64	0.7344	18.654
3/4	0.75	19.05
49/64	0.7656	19.446
25/32	0.7813	19.845
51/64	0.7969	20.241
13/16	0.8125	20.637
53/64	0.8281	21.034
27/32	0.8438	21.433
55/64	0.8594	21.829
7/8	0.875	22.225
57/64	0.8906	22.621
29/32	0.9063	23.02
59/64	0.9219	23.416
15/16	0.9375	23.812
61/64	0.9531	24.209
31/32	0.9688	24.608
63/64	0.9844	25.004
1	1	25.4



Fasteners

SHP

Rivets

Aluminum Brazier Head

	Diameter	Length	Head Diameter	Material	Count Per Pound
RVT6-222A	3/16 in.	3/8 in.	1/2 in.	Soft	523
RVT6-222	3/16 in.	3/8 in.	1/2 in.	Hard	523
RVT6-223A	3/16 in.	7/16 in.	1/2 in.	Soft	480
RVT6-223	3/16 in.	7/16 in.	1/2 in.	Hard	480
RVT6-224A	3/16 in.	1/2 in.	1/2 in.	Soft	443
RVT6-224	3/16 in.	1/2 in.	1/2 in.	Hard	443
RVT6-225	3/16 in.	9/16 in.	1/2 in.	Hard	411
RVT6-226A	3/16 in.	5/8 in.	1/2 in.	Soft	384
RVT6-226	3/16 in.	5/8 in.	1/2 in.	Hard	384
RVT6-228	3/16 in.	3/4 in.	1/2 in.	Hard	338
RVT6-262	1/4 in.	3/8 in.	5/8 in.	Hard	257
RVT6-263	1/4 in.	7/16 in.	5/8 in.	Hard	238
RVT6-264A	1/4 in.	1/2 in.	5/8 in.	Soft	222
RVT6-264	1/4 in.	1/2 in.	5/8 in.	Hard	222
RVT6-265	1/4 in.	9/16 in.	5/8 in.	Hard	208
RVT6-266A	1/4 in.	5/8 in.	5/8 in.	Soft	195
RVT6-266	1/4 in.	5/8 in.	5/8 in.	Hard	195
BRV00005	1/4 in.	11/16 in.	5/8 in.	Hard	184
RVT6-268	1/4 in.	3/4 in.	5/8 in.	Hard	175
RVT6-269	1/4 in.	13/16 in.	5/8 in.	Hard	189
RVT6-27	1/4 in.	7/8 in.	5/8 in.	Hard	157
RVT6-271	1/4 in.	1 in.	5/8 in.	Hard	143
RVT6-28	1/4 in.	15/16 in.	5/8 in.	Hard	150
RVT6-68	3/8 in.	3/4 in.	15/16 in.	Hard	66
RVT6-307	5/16 in.	5/8 in.	3/4 in.	Hard	113
RVT6-309	5/16 in.	3/4 in.	3/4 in.	Hard	102



Fasteners

SHP

Rivets

Aluminum Modified Brazier Head

	Diameter	Length	Head Diameter	Count Per Pound
RVT10-222	3/16 in.	3/8 in.	7/16 in.	649
RVT10-223	3/16 in.	7/16 in.	7/16 in.	584
RVT10-224	3/16 in.	1/2 in.	7/16 in.	531
RVT10-262	1/4 in.	3/8 in.	1/2 in.	369
RVT10-263	1/4 in.	7/16 in.	1/2 in.	331
RVT10-264	1/4 in.	1/2 in.	1/2 in.	300
RVT10-265	1/4 in.	9/16 in.	1/2 in.	274
RVT10-266	1/4 in.	5/8 in.	1/2 in.	253
RVT10-268	1/4 in.	3/4 in.	1/2 in.	218
RVT10-272	1/4 in.	1-1/8 in.	1/2 in.	155
RVT10-273	1/4 in.	1-1/8 in.	1/2 in.	155
RVT10-310	5/16 in.	5/16 in.	13/16 in.	121
RVT10-311	5/16 in.	5/16 in.	7/8 in.	113
RVT10-307	5/16 in.	5/8 in.	5/8 in.	145
RVT10-309	5/16 in.	3/4 in.	5/8 in.	128

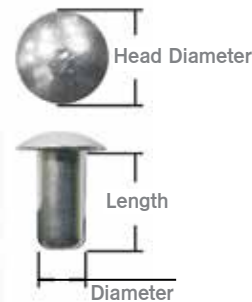

Aluminum Universal Head

	Diameter	Length	Head Diameter	Count Per Pound
RVT1-222	3/16 in.	3/8 in.	3/8 in.	633
RVT1-223	3/16 in.	7/16 in.	3/8 in.	571
RVT1-224	3/16 in.	1/2 in.	3/8 in.	521
RVT1-226	3/16 in.	5/8 in.	3/8 in.	441
RVT1-262	1/4 in.	3/8 in.	1/2 in.	306
RVT1-263	1/4 in.	7/16 in.	1/2 in.	279
RVT1-264	1/4 in.	1/2 in.	1/2 in.	257
RVT1-266	1/4 in.	5/8 in.	1/2 in.	222
RVT1-268	1/4 in.	3/4 in.	1/2 in.	195
RVT1-27	1/4 in.	7/8 in.	1/2 in.	174
RVT1-271	1/4 in.	1 in.	1/2 in.	157
RVT1-305	5/16 in.	1/2 in.	5/8 in.	151
RVT1-307	5/16 in.	5/8 in.	5/8 in.	132
RVT1-309	5/16 in.	3/4 in.	5/8 in.	117
RVT1-310	5/16 in.	7/8 in.	1/2 in.	105
RVT1-67	3/8 in.	5/8 in.	29/64 in.	69
RVT1-68	3/8 in.	3/4 in.	3/4 in.	81
RVT1-69	3/8 in.	13/16 in.	3/4 in.	77
RVT1-7	3/8 in.	7/8 in.	3/4 in.	73
RVT1-71	3/8 in.	1 in.	3/4 in.	66

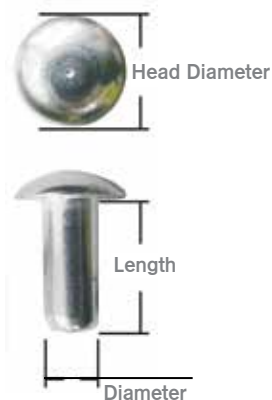

Fasteners

SHP

Rivets

Monobolt Pull

	Mandrel	Body	Type	Diameter	Length	Grip Range
AVD2774-0617	Aluminum	Aluminum	Protruding	3/16 in.	37/64 in.	0.062 - 0.437
AVD2774-0817	Aluminum	Aluminum	Protruding	1/4 in.	9/16 in.	0.080 - 0.375
AVD2774-0824	Aluminum	Aluminum	Protruding	1/4 in.	35/64 in.	0.080 - 0.625
HUKMGLPB810	Aluminum	Aluminum	Protruding	1/4 in.	13/16 in.	0.350 - 0.625
HUKMGLP-B8-E	Aluminum	Aluminum	Protruding	1/4 in.	33/64 in.	0.080 - 0.625
HUKMGLPR64	Steel	Steel	Protruding	3/16 in.	27/64 in.	0.062 - 0.270
HUKMGLPR67	Steel	Steel	Protruding	3/16 in.	37/64 in.	0.214 - 0.437
RVB60558600	Steel	Steel	Protruding	1/4 in.	9/16 in.	0.080 - 0.375
RVB60558100	Steel	Steel	Protruding	1/4 in.	13/16 in.	0.350 - 0.625
HUKMGL100-R8-8	Steel	Steel	Countersunk	1/4 in.	13/32 in.	0.160 - 0.475
AVD2711-0817	Stainless Steel	Stainless Steel	Protruding	1/4 in.	9/16 in.	0.080 - 0.375
HUKMGL100-U8-8	Stainless Steel	Stainless Steel	Countersunk	1/4 in.	21/32 in.	0.160 - 0.475
HUKMGLPU810	Stainless Steel	Stainless Steel	Protruding	1/4 in.	33/64 in.	0.350 - 0.625



Lock Bolt

	Diameter	Length	Grip Range	Material
WABPRV00241	3/8 in.	1 in.	0.812 - 1.063	Steel



Lock Bolt Collar

	Type	Diameter	Material
HUKMGC-R6U	Standard	3/16 in.	Steel
HUKMGC-R8U	Standard	1/4 in.	Steel
HUKHBMGCF12	Standard	3/8 in.	Aluminum
HUKHBMGCR12U	Standard	3/8 in.	Steel
WABPRV00242	Flanged	3/8 in.	Steel



Shaveable Rivet

	Type	Mandrel	Body	Diameter	Length	Grip Range
LAFXOYRV660788W	Kit of 25	Aluminum	Aluminum	1/4 in.	1/2 in.	0.050 - 0.500



Fasteners

SHP

Rivets

Pop Pull

	Type	Mandrel	Body	Diameter	Length	Grip Range
POPAD64ABS	Standard	Aluminum	Aluminum	3/16 in.	7/16 in.	0.126 - 0.250
POPAD66ABS	Standard	Aluminum	Aluminum	3/16 in.	37/64 in.	0.251 - 0.375
POPAD612ABS	Standard	Aluminum	Aluminum	3/16 in.	15/16 in.	0.626 - 0.750
POPAD812ABS	Standard	Aluminum	Aluminum	1/4 in.	1 in.	0.501 - 0.750
POPAD64BS	Standard	Steel	Aluminum	3/16 in.	7/16 in.	0.126 - 0.250
POPAD66BS	Standard	Steel	Aluminum	3/16 in.	37/64 in.	0.251 - 0.375
POPAD68BS	Standard	Steel	Aluminum	3/16 in.	11/16 in.	0.376 - 0.500
POPAD610BS	Standard	Steel	Aluminum	3/16 in.	13/16 in.	0.501 - 0.625
POPXAD84BS	Standard	Steel	Aluminum	1/4 in.	31/64 in.	0.063 - 0.250
POPXAD86BS	Standard	Steel	Aluminum	1/4 in.	5/8 in.	0.251 - 0.375
POPXAD88BS	Standard	Steel	Aluminum	1/4 in.	47/64 in.	0.376 - 0.500
POPXAD810BS	Standard	Steel	Aluminum	1/4 in.	7/8 in.	0.501 - 0.625
POPXAD812BS	Standard	Steel	Aluminum	1/4 in.	63/64 in.	0.626 - 0.750
POPXAD816BS	Standard	Steel	Aluminum	1/4 in.	1-15/64 in.	0.751 - 1.00
POPADSD86BS	Standard	Steel	Steel	1/4 in.	5/8 in.	0.251 - 0.375
POPADSD88BS	Standard	Steel	Steel	1/4 in.	47/64 in.	0.376 - 0.500
POPAD62AH	Sealed	Aluminum	Aluminum	3/16 in.	21/64 in.	0.063 - 0.125
POPAD64AH	Sealed	Aluminum	Aluminum	3/16 in.	7/16 in.	0.126 - 0.250
POPAD66AH	Sealed	Aluminum	Aluminum	3/16 in.	37/64 in.	0.251 - 0.375
POPAD62H	Sealed	Steel	Aluminum	3/16 in.	21/64 in.	0.063 - 0.125
POPAD64H	Sealed	Steel	Aluminum	3/16 in.	7/16 in.	0.126 - 0.250
POPAD66H	Sealed	Steel	Aluminum	3/16 in.	37/64 in.	0.251 - 0.375
POPAD68H	Sealed	Steel	Aluminum	3/16 in.	11/16 in.	0.376 - 0.500
POPAD66ABSLF	Large Flange	Aluminum	Aluminum	3/16 in.	37/64 in.	0.251 - 0.375
POPAD66BSLF	Large Flange	Steel	Aluminum	3/16 in.	37/64 in.	0.251 - 0.375
POPAD68BSLF	Large Flange	Steel	Aluminum	3/16 in.	11/16 in.	0.376 - 0.500
POPAD610BSLF	Large Flange	Steel	Aluminum	3/16 in.	53/64 in.	0.501 - 0.625
POPAD612BSLF	Large Flange	Steel	Aluminum	3/16 in.	15/16 in.	0.626 - 0.750

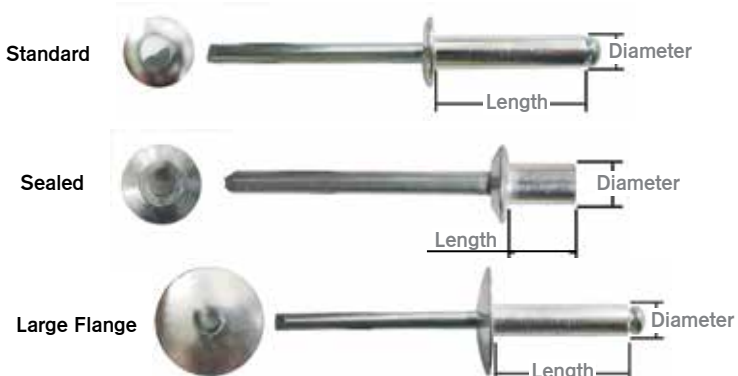

Fasteners

SHP

Rivets

Tapit

	Diameter	Length	Material	Pin	Count
RVB10-13-706-13	3/16 in.	3/8 in.	Aluminum	Aluminum	100
RVB2-2A	1/4 in.	3/4 in.	Nylon	Steel	100
RVB2-2B	1/4 in.	3/4 in.	Nylon	Steel	250
RVB2-2	1/4 in.	3/4 in.	Nylon	Steel	1,000
RVB2-3A	1/4 in.	1.00 in.	Nylon	Steel	100
RVB2-3B	1/4 in.	1.00 in.	Nylon	Steel	250
RVB2-3	1/4 in.	1.00 in.	Nylon	Steel	1,000
RVB2-4B	1/4 in.	1-1/2 in.	Nylon	Steel	250
RVB2-4	1/4 in.	1-1/2 in.	Nylon	Steel	500
RVB2-5	1/4 in.	2.00 in.	Nylon	Steel	500
RVB2-6B	1/4 in.	3.00 in.	Nylon	Steel	250
RVB2-6	1/4 in.	3.00 in.	Nylon	Steel	100
RVB1-1	1/4 in.	1.00 in.	Uni-tap	Nylon	1,000

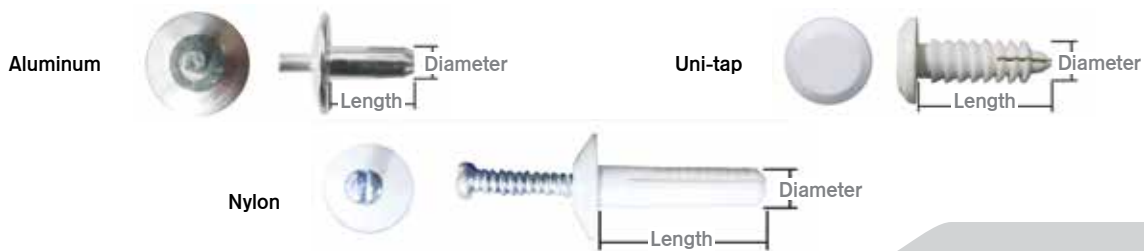

Installation Procedure

Pull Rivet

Step 1

Insert the mandrel into the nose tip of the tool. Vertically insert the rivet body in an assembly hole in the workpiece to be joined.

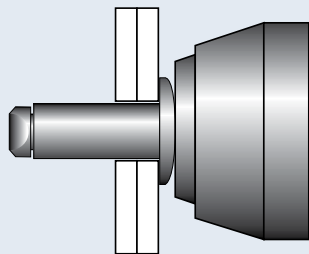

Step 3

The rivet is set by pulling the mandrel head into the rivet body, expanding it, and forming a strong, tight, reliable joint.

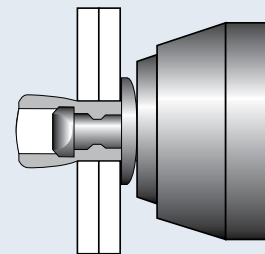

Step 2

Press the tool trigger. The jaws of the tool will catch hold of the mandrel.

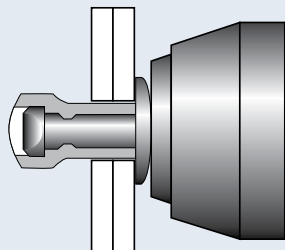

Step 4

When the predetermined force is applied, the mandrel breaks and falls away.

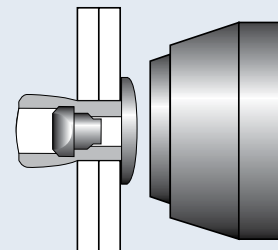

Fasteners

SHP

Screws

Torx Flat Head

	Diameter	Thread	Length	Material	Count
PROF5-516	1/4 in.	20	1 in.	Steel	100
PROF5-516B	1/4 in.	20	1 in.	Steel	1,000
PROF5-521	1/4 in.	20	1-1/4 in.	Steel	100
PROF5-521B	1/4 in.	20	1-1/4 in.	Steel	1,000
PROF5-527	1/4 in.	20	1-1/2 in.	Steel	100
PROF5-527B	1/4 in.	20	1-1/2 in.	Steel	1,000
PROF5-538	1/4 in.	20	2 in.	Steel	100
PROF5-538B	1/4 in.	20	2 in.	Steel	2,000
PROF5-543	1/4 in.	20	2-1/4 in.	Steel	100
PROF5-543B	1/4 in.	20	2-1/4 in.	Steel	1,500
PROF5-549	1/4 in.	20	2-1/2 in.	Steel	100
PROF5-549B	1/4 in.	20	2-1/2 in.	Steel	1,200
PROF5-560	1/4 in.	20	3 in.	Steel	100
PROF5-560B	1/4 in.	20	3 in.	Steel	1,000
PROF5-580	1/4 in.	20	4 in.	Steel	50
PROF5-580B	1/4 in.	20	4 in.	Steel	700
PROF5-603	1/4 in.	20	5 in.	Steel	50
PROF5-603B	1/4 in.	20	5 in.	Steel	1,000
SCR5-624	1/4 in.	20	6 in.	Steel	25
PROF5-635	5/16 in.	18	3/4 in.	Steel	100
PROF5-640	5/16 in.	18	1 in.	Steel	100
PROF5-640B	5/16 in.	18	1 in.	Steel	2,000
PROF5-646	5/16 in.	18	1-1/4 in.	Steel	100
PROF5-651	5/16 in.	18	1-1/2 in.	Steel	100
PROF5-651B	5/16 in.	18	1-1/2 in.	Steel	1,800
PROF5-662	5/16 in.	18	2 in.	Steel	100
PROF5-662B	5/16 in.	18	2 in.	Steel	1,250
PROF5-668	5/16 in.	18	2-1/4 in.	Steel	100
PROF5-668B	5/16 in.	18	2-1/4 in.	Steel	1,000
PROF5-673	5/16 in.	18	2-1/2 in.	Steel	100
PROF5-673B	5/16 in.	18	2-1/2 in.	Steel	900
PROF5-684B	5/16 in.	18	3 in.	Steel	750
PROF5-690	5/16 in.	18	4 in.	Steel	50
PROF5-690B	5/16 in.	18	4 in.	Steel	500
PROF5-691	5/16 in.	18	5 in.	Steel	1
SCWF8799767-0182	11/32 in.	18	2-1/4 in.	Steel	1,000

Self Threading

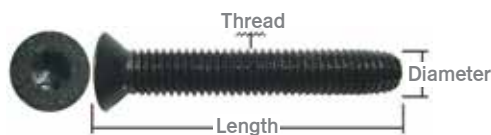

pro-par
OUR PARTS. YOUR PARTS.

Fasteners

SHP

Screws

Hex Washer Head Tek

Length	#10 - 16	#12 - 14	#14 - 14
1/2 in.	SCR-SMSTKH1002		
5/8 in.	SCR-SMSTKH1005		
3/4 in.	SCR-SMSTKH1003	SCR-SMSTKH1203	SCR-SMSTKH1403
1 in.	SCR-SMSTKH1010	SCR-SMSTKH1210	SCR-SMSTKH1410
1-1/4 in.	SCR-SMSTKH1011	SCR-SMSTKH1211	
1-1/2 in.	SCR-SMSTKH1012	SCR-SMSTKH1212	SCR-SMSTKH1412
1-3/4 in.			SCR-SMSTKH1413
2 in.	SCR-SMSTKH1020	SCR-SMSTKH1220	SCR-SMSTKH1420
2-1/2 in.			SCR-SMSTKH1422
3 in.			SCR-SMSTKH1430

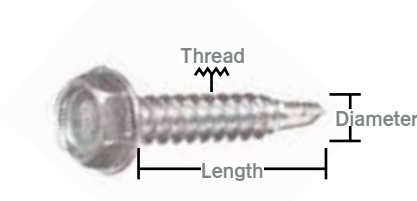

Pro-Par

Hex Washer Head Tek

Diameter	Thread	Length	
#10	16	3/4 in.	SCR-SSSMSTKH1003
#10	16	1 in.	SCR-SSSMSTKH1010
#10	16	1-1/2 in.	SCR-SSSMSTKH1012

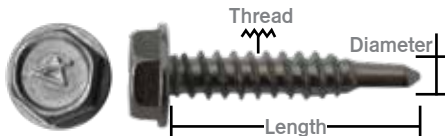

Stainless Steel

Pro-Par

Phillips Plywood Lining

Diameter	Thread	Length	
#10	24	3/4 in.	SCR-SMSTKW1003
#10	24	1 in.	SCR-SMSTKW1010
#10	24	1-1/2 in.	SCR-SMSTKW1012

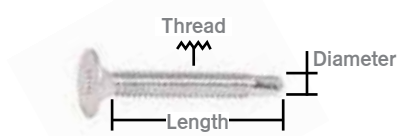

Pro-Par

Phillips Pan Head Tek

Length	#6 - 20	#8 - 18	#10 - 16
1/2 in.	SCR-SMSTKP0602	SCR-SMSTKP0802	SCR-SMSTKP1002
5/8 in.			SCR-SMSTKP1005
3/4 in.	SCR-SMSTKP0603	SCR-SMSTKP0803	SCR-SMSTKP1003
1 in.	SCR-SMSTKP0610	SCR-SMSTKP0810	SCR-SMSTKP1010
1-1/2 in.			SCR-SMSTKP1012

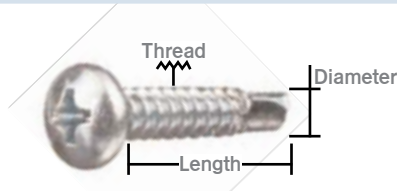

Pro-Par

Fasteners



SHP

Screws

Specialty

	Diameter	Thread	Length	Material	Additional Information
BLT00646					E-Track
BBTP7440-0026	5/16 in.	18	1-1/2 in.		T40, 6 Lobe
MTR1199K3859					Set Screw
SCR5-45656	5/16 in.	18	1-1/4 in.		Pan Head Torx
SCR6-649	5/16 in.	18	1-3/4 in.	Steel	Thread Cutting Pan Head Torx
SCR12-662A	5/16 in.	18	2 in.	Zinc Plated/ Steel	Thread Forming Pan Head Torx
SCR60270420	#10	16	1-1/4 in.	Steel	Plywood
SCRSTLPL1003	#10		3/4 in.		Liner
SCRSTLPL1010	#10		1 in.		Liner
WABBLT01004	#10	24	1/2 in.	Zinc	Pan Head
SCWF3911669-99	#6		1 in.		Deck
SCWF8719744-3582	#16	10	2 in.		Pan Head Torx
TSCNCA-055	13/64 in.	24	1 in.	Stainless Steel	Pan Head Torx - Type F
WABBLT00081	5/16 in.	18	2-1/2 in.		Thread Forming Floor Screw



(TSCNCA-055)

(SCR6-649)

(SCR12-662A)

(SCR60270420)

Identification

Drives

Screw Types



Slotted



One-Way Slot



Phillips (Type 1)



Phillips/Slot Combination



Phillips (Type 1A)



1A/Slot Combination



Phillips/Hex



Fearnson (Type 2)



Quadrex Combination



Square



Square/Slot Combination



Hex Socket



Hex



Hex Washer

Head Styles



Flat 82°



Flat Undercut



Flat 100°



Oval



Oval Undercut



Pan



Round



Binding



Truss



Hexagon



Washer



Hex Washer



Plain



Fillister



Hex Washer Slotted

Washers

Fender

Inner Diameter	Outer Diameter	Grade 5, Plain	Stainless Steel
1/4 in.	1-1/4 in.	WSH-WWF04	WSH-SSWWF04
5/16 in.	1-1/4 in.		WSH-SSWWF0511
5/16 in.	1-1/2 in.	WSH-WWF05	WSH-SSWWF05
3/8 in.	1-1/4 in.	WSH-WWF06	WSH-SSWWF06
3/8 in.	1-1/2 in.		WSH-SSWWF0612



Pro-Par

Flat

Inner Diameter	Grade 5, USS	Grade 8, USS	Grade 5, SAE	Grade 8, SAE
1/4 in.	WSH-WWU04	WSH-WWU804	WSH-WWS04	WSH-WWS804
5/16 in.	WSH-WWU05	WSH-WWU805	WSH-WWS05	WSH-WWS805
3/8 in.	WSH-WWU06	WSH-WWU806	WSH-WWS06	WSH-WWS806
7/16 in.	WSH-WWU07	WSH-WWU807	WSH-WWS07	WSH-WWS807
1/2 in.	WSH-WWU08	WSH-WWU808	WSH-WWS08	WSH-WWS808
5/8 in.	WSH-WWU10	WSH-WWU810	WSH-WWS10	WSH-WWS810
3/4 in.	WSH-WWU12	WSH-WWU812	WSH-WWS12	WSH-WWS812
7/8 in.	WSH-WWU14	WSH-WWU814	WSH-WWS14	WSH-WWS814
1 in.	WSH-WWU16	WSH-WWU816	WSH-WWS16	WSH-WWS816

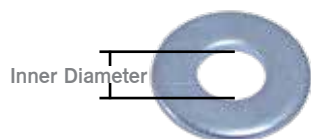

Pro-Par

Lock

Inner Diameter	Grade 5, Low Carbon Plated	Grade 8, Plated
1/4 in.	WSH-WWL04	WSH-WWL804
5/16 in.	WSH-WWL05	WSH-WWL805
3/8 in.	WSH-WWL06	WSH-WWL806
7/16 in.	WSH-WWL07	WSH-WWL807
1/2 in.	WSH-WWL08	WSH-WWL808
5/8 in.	WSH-WWL10	WSH-WWL810
3/4 in.	WSH-WWL12	WSH-WWL812

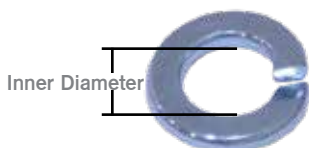

Pro-Par

Fasteners

SHP

Washers

Specialty

	Type	Inner Diameter	Outer Diameter	Material
FRUFCA5557				
WSHF4821008-07	Hardened	3/8 in.		
WSH77613	Flat SAE	13/32 in.	13/16 in.	Steel
WSH-CC01	Ram Mount			10 ga. Steel
WSH-WWLI16	Internal Lock	1 in.		Grade 5
WSH-WWL810	Lock	5/8 in.		Grade 8
WSH-WWS808	Flat	1/2 in.		Grade 8



Dimensions

USS and SAE Washers

Size	USS			SAE		
	Inside Diameter (A)	Outside Diameter (B)	Thickness (C)	Inside Diameter (A)	Outside Diameter (B)	Thickness (C)
#2	-	-	-	0.094	0.250	0.020
#4	-	-	-	0.125	0.313	0.032
#6	-	-	-	0.156	0.375	0.049
#8	-	-	-	0.188	0.438	0.049
#10	-	-	-	0.219	0.500	0.049
#12	-	-	-	0.250	0.563	0.065
0.250	0.313	0.734	0.065	0.281	0.625	0.065
0.313	0.375	0.875	0.083	0.344	0.688	0.065
0.375	0.438	1.000	0.083	0.406	0.813	0.065
0.438	0.500	1.250	0.083	0.469	0.938	0.065
0.500	0.563	1.375	0.109	0.531	1.063	0.095
0.563	0.625	1.469	0.109	0.594	1.156	0.095
0.625	0.688	1.750	0.134	0.656	1.313	0.095
0.750	0.813	2.000	0.148	0.813	1.469	0.134
0.875	0.938	2.250	0.165	0.938	1.750	0.134
1.000	1.063	2.500	0.165	1.063	2.000	0.134
1.125	1.250	2.750	0.165	-	-	-
1.250	1.375	3.00	0.165	-	-	-
1.375	1.500	3.250	0.180	-	-	-
1.500	1.625	3.500	0.180	-	-	-
1.625	1.750	3.750	0.180	-	-	-
1.750	1.875	4.000	0.180	-	-	-
2.000	2.125	4.500	0.213	-	-	-

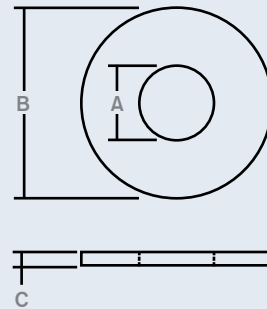

USS Washer

The United States Standards (USS) is a standard for inch based washers. USS washers are often characterized as having slightly larger inside diameter & outside diameter to accommodate coarse or larger bolt threads.

SAE Washer

The Society of Automotive Engineers (SAE) standard washers. These washers are often characterized by being produced from a thinner material & having slightly smaller inside diameters & outside diameters than standard USS Washers.

Aluminum Roof

Roof Fasteners

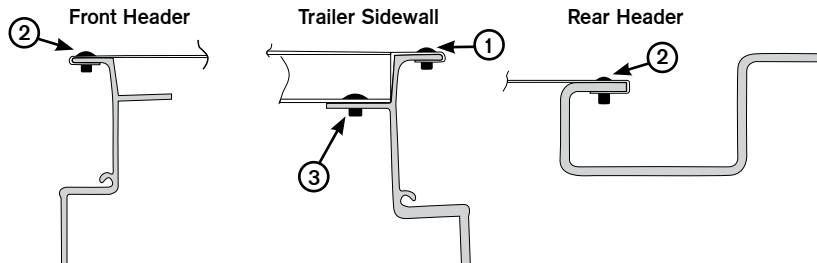

Item	Part Number	Diameter	Length	Head Diameter	Description
1	RVT6-222	0.19 in.	0.38 in.	0.50 in.	Aluminum brazier head buck rivet
2	RVT6-224	0.19 in.	0.50 in.	0.50 in.	Aluminum brazier head buck rivet
3	RVT6-262	0.25 in.	0.38 in.	0.63 in.	Aluminum brazier head buck rivet

Translucent Roof

Roof Fasteners

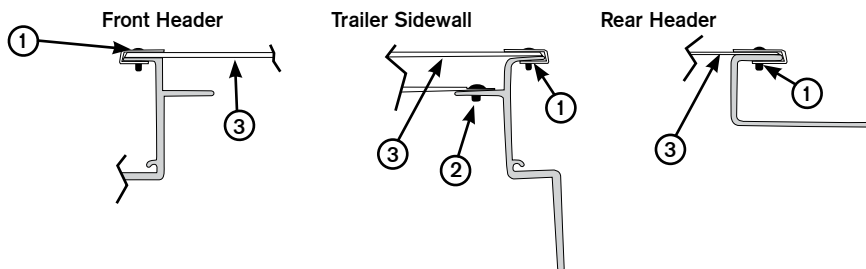

Item	Part Number	Diameter	Length	Head Diameter	Description
1	RVT6-224	0.19 in.	0.50 in.	0.50 in.	Aluminum brazier head buck
2	RVT6-262	0.25 in.	0.38 in.	0.63 in.	Aluminum brazier head buck
3	FRUSTK30145-50[^]	0.040 in. x 1-1/2 in. x 50 ft.			Aluminum double strip

Accessories

- Blind Rivet
AVD2774-0824
- J Moulding
WABE0821200

[^]Part included for reference only.

FRP Roof

Roof Fasteners

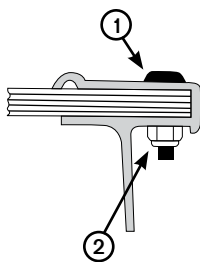

Item	Part Number	Diameter	Thread	Length	Description
1	SCW60753087	0.31 in.	18	1.38 in.	Torx style truss head bolt
2	NUT-HNUST05	0.31 in.	18		Nylon lock nut

Smooth Aluminum Nose

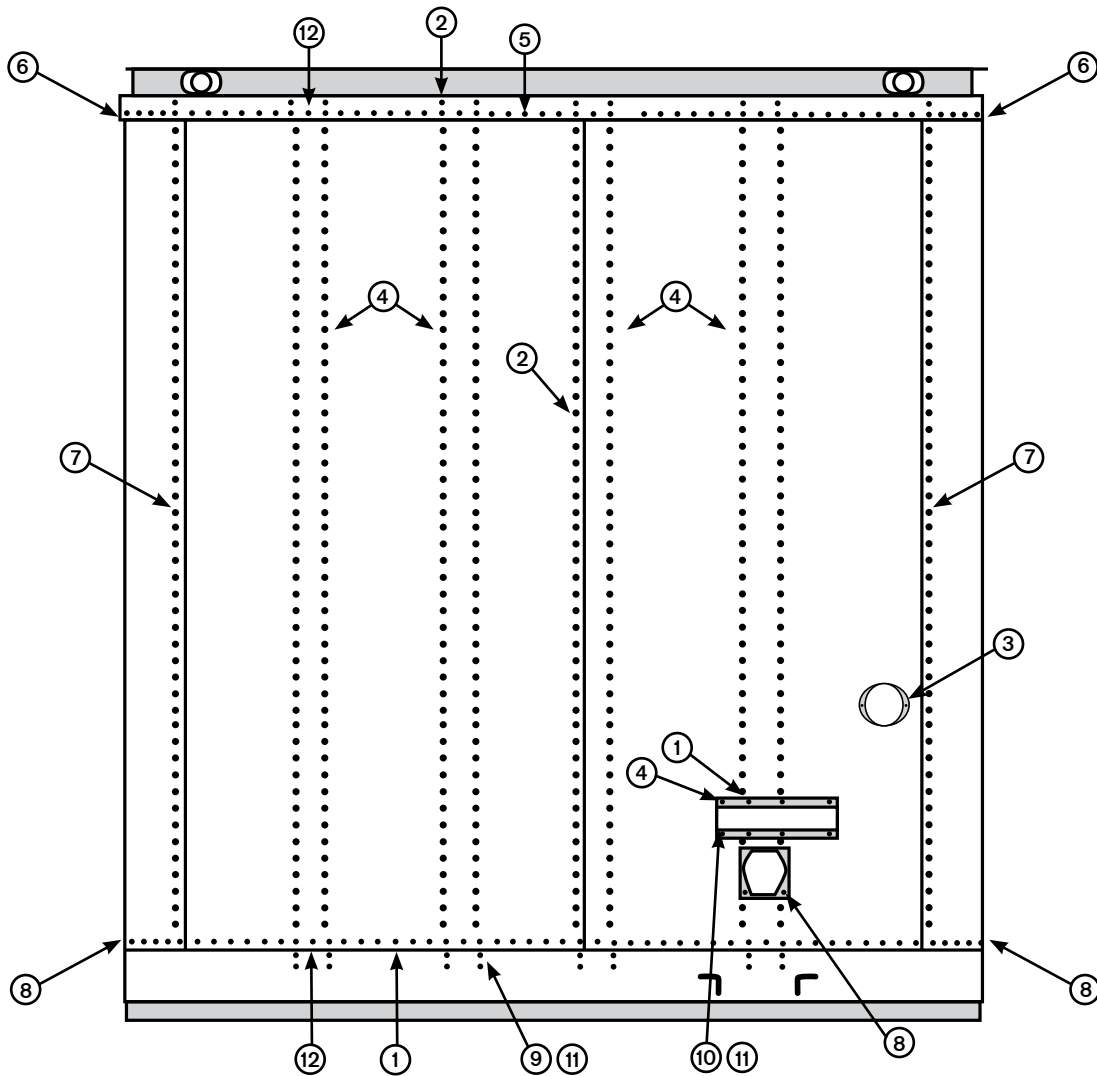

Fasteners Tech

SHP

Item	Part Number	Diameter	Length	Head Diameter	Description
1	RVT6-265	1/4 in.	9/16 in.	5/8 in.	Aluminum brazier head rivet
2	RVT1-263	1/4 in.	7/16 in.	1/2 in.	Aluminum universal head rivet
3	RVT6-222	3/16 in.	3/8 in.	1/2 in.	Aluminum brazier head rivet
4	RVT6-262	1/4 in.	3/8 in.	5/8 in.	Aluminum brazier head rivet
5	RVT10-262	1/4 in.	3/8 in.	1/2 in.	Alum. modified brazier head rivet
6	RVT6-265	1/4 in.	9/16 in.	5/8 in.	Aluminum brazier head rivet
7	RVT6-264	1/4 in.	1/2 in.	5/8 in.	Aluminum brazier head rivet
8	RVT6-266	1/4 in.	5/8 in.	5/8 in.	Aluminum brazier head rivet
9	BLT60753008	5/16 in.	1 in.	Thread: 18	Hex Bolt
10	BLT2-153[^]	5/16 in.	1 in.	Thread: 18	Carriage Bolt
11	NUT-HNUST05	5/16 in.	-	Thread: 18	Hex lock nut
12	AVD2774-0817	1/4 in.	9/19 in.	-	Aluminum monobolt rivet

[^]Part included for reference only.

Aluminum Plate Nose

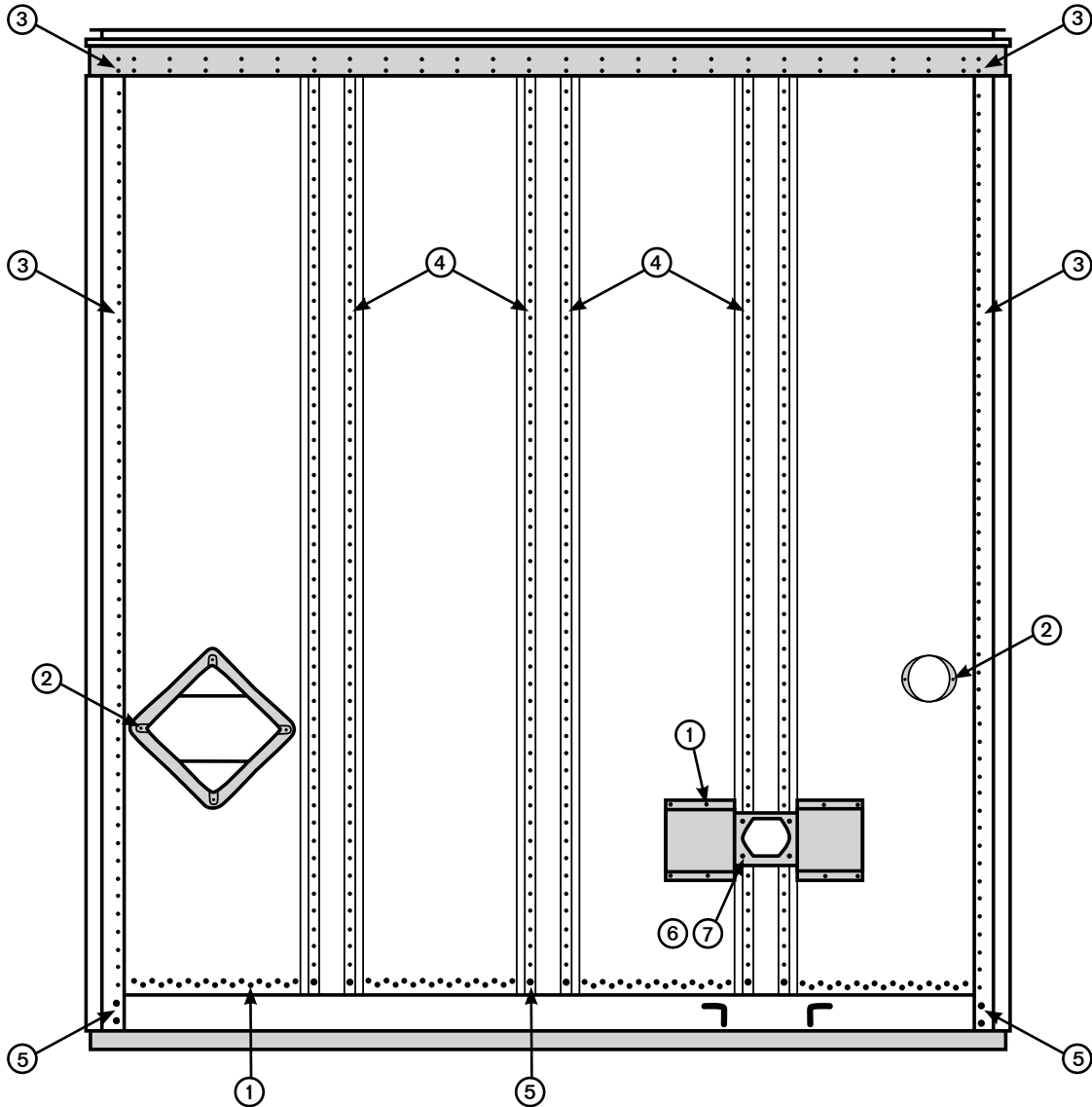

Item	Part Number	Diameter	Length	Head Diameter	Description
1	RVT1-263	1/4 in.	7/16 in.	1/2 in.	Aluminum universal head rivet
2	RVT6-224	3/16 in.	1/2 in.	1/2 in.	Aluminum brazier head rivet
3	RVT6-266	1/4 in.	5/8 in.	5/8 in.	Aluminum brazier head rivet
4	RVT10-268	1/4 in.	3/4 in.	1/2 in.	Aluminum modified brazier head rivet
5	RVT6-271	1/4 in.	1 in.	5/8 in.	Aluminum brazier head rivet
6	BLT2-153[^]	5/16 in.	1 in.	Thread: 18	Carriage bolt
7	NUT-HNUST05	5/16 in.	-	Thread: 18	Hex lock nut

[^]Part included for reference only.

DuraPlate® Nose

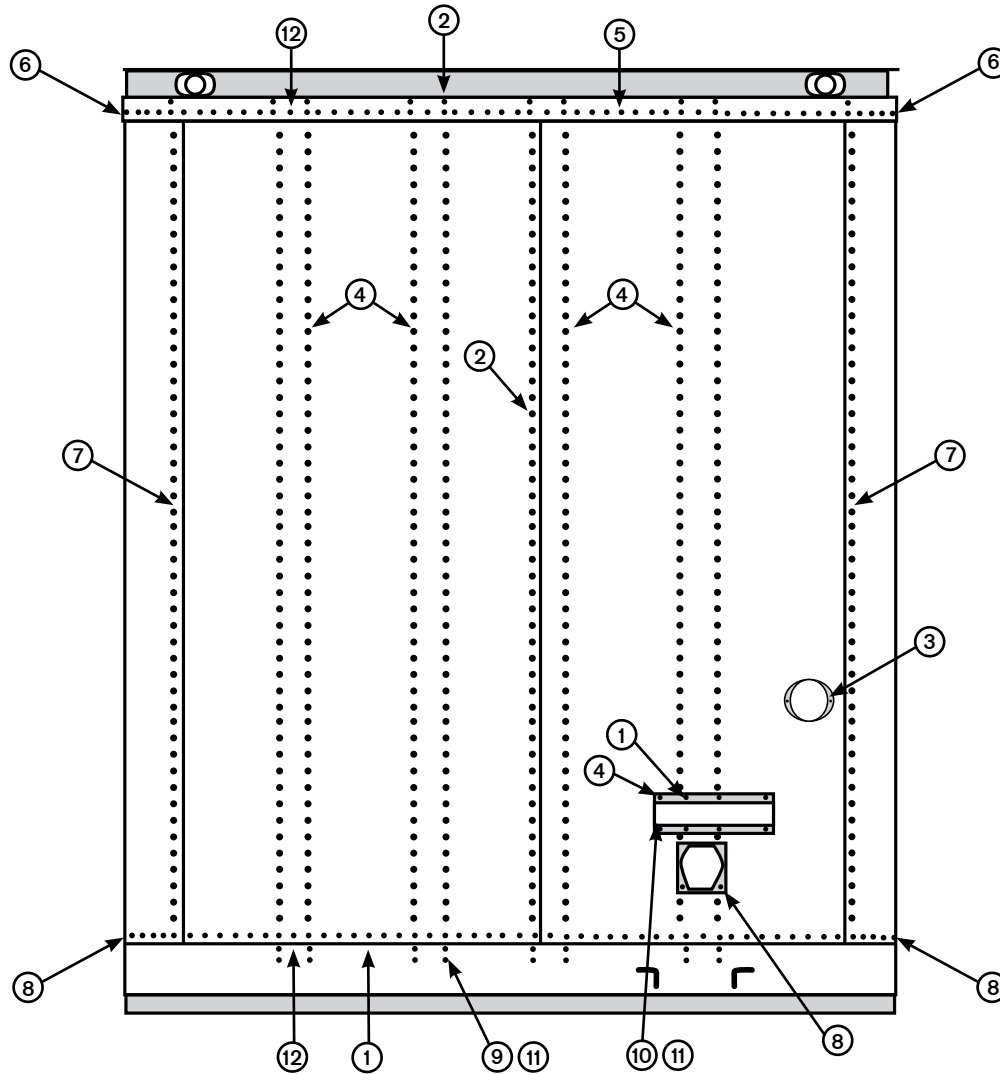

Fasteners Tech

SHP

Item	Part Number	Diameter	Length	Head Diameter	Description
1	RVT6-264	1/4 in.	1/2 in.	5/8 in.	Aluminum brazier head rivet
2	RVT6-265	1/4 in.	9/16 in.	5/8 in.	Aluminum brazier head rivet
3	RVT6-222	3/16 in.	3/8 in.	1/2 in.	Aluminum brazier head rivet
4	RVT1-263	1/4 in.	7/16 in.	1/2 in.	Aluminum universal head rivet
5	RVT1-262	1/4 in.	3/8 in.	1/2 in.	Aluminum universal head rivet
6	RVT6-266	1/4 in.	5/8 in.	5/8 in.	Aluminum brazier head rivet
7	RVT6-264	1/4 in.	1/2 in.	5/8 in.	Aluminum brazier head rivet
8	RVT6-266	1/4 in.	5/8 in.	5/8 in.	Aluminum brazier head rivet
9	BLT60753008	5/16 in.	1 in.	Thread: 18	Hex bolt
10	NUT-HNUST05	5/16 in.		Thread: 18	Hex lock nut
11	BLT11-230	5/16 in.	3/4 in.	Thread: 18	Carriage bolt
12	AVD2774-0817	1/4 in.	9/16 in.		Aluminum monobolt rivet

FRP Nose

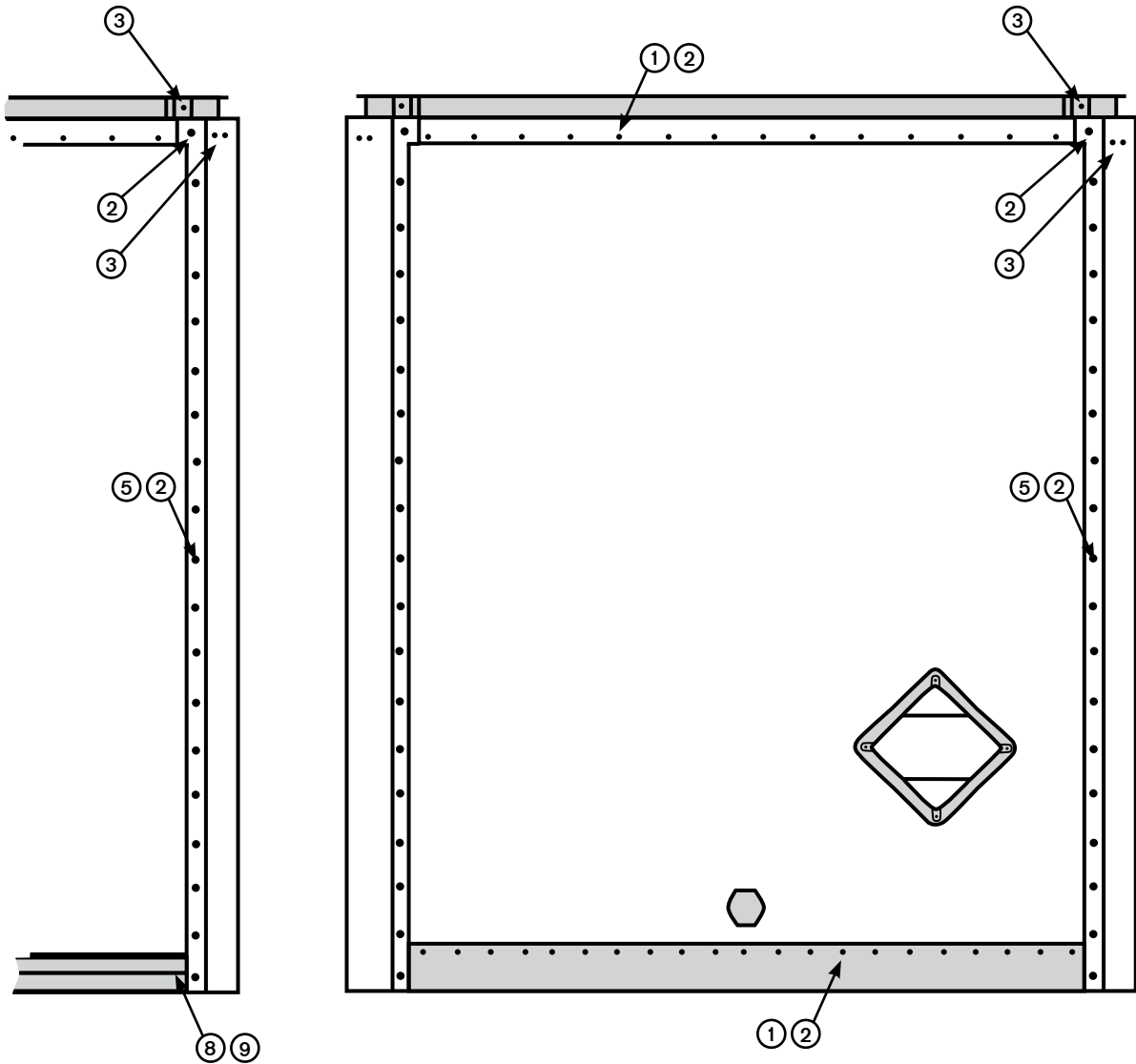

Fasteners Tech

SHP

Item	Part Number	Diameter	Length	Head Diameter	Description
1	BLT60753008	5/16 in.	1 in.	Thread: 18	Hex head bolt
2	NUT60752006	5/16 in.	5/8 in.	Thread: 18	Tee nut
3	RVT6-271	1/4 in.	1 in.	5/8 in.	Aluminum brazier head rivet
4	BLT60753008	5/16 in.	1 in.	Thread: 18	Hex head bolt
5	BLT9-9S	3/8 in.	1-7/8 in.	Thread: 16	Encapsulated FRP bolt
6	NUT-HNUNY806	3/8 in.	-	Thread: 16	Nylon lock nut

Smooth Aluminum Side

Item	Part Number	Diameter	Length	Head Diameter	Description / Attaches
1	RVT6-265	1/4 in.	9/16 in.	5/8 in.	Aluminum brazier head rivet [side post to top rail at non-lap] [side sheet to rear attachment] [side sheet to front crossmember] [side sheet to base rail at non-lap] [side post to top rail at sheet-lap] [side post to base rail at sheet-top]
2	RVT1-263	1/4 in.	7/16 in.	1/2 in.	Aluminum universal head rivet [side sheet to post at lap] [between side post & base rail] [between side post & top rail] [side sheet to side post at non-lap]
3	RVT6-266	1/4 in.	5/8 in.	5/8 in.	Aluminum brazier head rivet [base rail to rear attachment strip]
4	AVD2774-0817	1/4 in.	9/16 in.	-	Aluminum monobolt rivet [center of side post to top rail] [center of side post to base rail]
5	BLT60753162	3/8 in.	1 in.	Thread: 24	Button head base rail bolt [to secure crossmembers to base rail]
6	NUT-HNSNY06	3/8 in.	-	Thread: 24	Nylon lock nut [to secure crossmembers to base rail]

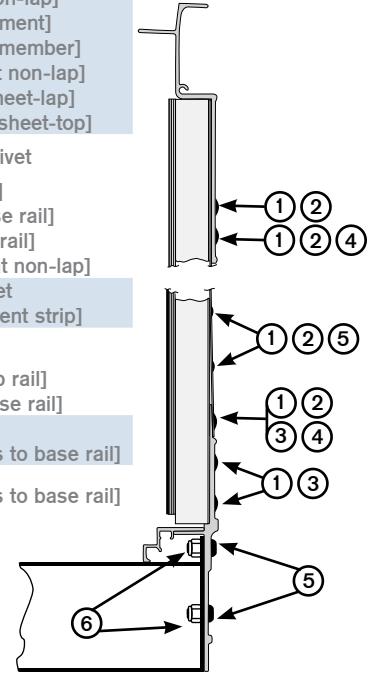

Aluminum Plate Side

Item	Part Number	Diameter	Length	Head Diameter	Description / Attaches
1	BLT60753162	3/8 in.	1 in.	Thread: 24	Button head base rail bolt [use at base rail to crossmember]
2	NUT-HNSNY06	3/8 in.	-	Thread: 24	Nylon lock nut [use at base rail to crossmember]
3	RVT6-266	1/4 in.	5/8 in.	5/8 in.	Aluminum brazier head rivet [used at top rail at side post & between] [use at rear attachment & sheet] [use at front corner & sheet]
4	RVT10-268	1/4 in.	3/4 in.	1/2 in.	Aluminum modified brazier head rivet [use at side post & sheet]
5	RVT60354400	1/4 in.	3/4 in.	-	Aluminum countersunk rivet [use at side post & sheet] [bottom 5 rivets only]

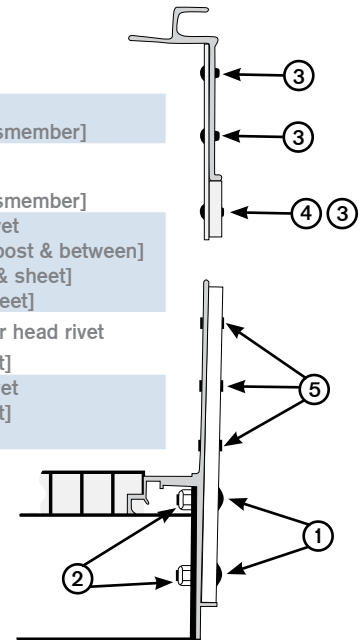

SHP Fasteners Tech

DuraPlate® 0.251 in. Side

Item	Part Number	Diameter	Length	Head Diameter	Description / Attaches
1	RVT6-268	1/4 in.	3/4 in.	5/8 in.	Aluminum brazier head rivet [top rail to side sheet] [side sheet to bottom rail]
2	RVT6-269	1/4 in.	13/16 in.	5/8 in.	Aluminum brazier head rivet [top rail to side sheet] [use for HD rail]
3	RVT6-265	1/4 in.	9/16 in.	5/8 in.	Aluminum brazier head rivet [side sheet to side sheet]
4	RVT1-265	1/4 in.	9/16 in.	-	Aluminum universal head rivet [side sheet to side sheet]
5	BLTF8721668-96	3/8 in.	1 in.	Thread: 16	Button head base rail bolt [bottom rail to crossmembers]
6	NUT-HNUNY806	3/8 in.	-	Thread: 16	Nylon lock nut [bottom rail to crossmembers]

DuraPlate® 0.331 in. Side

Item	Part Number	Diameter	Length	Head Diameter	Description / Attaches
1	RVT6-269	1/4 in.	13/16 in.	5/8 in.	Aluminum brazier head rivet [top rail to side sheet] [use for HD rail]
2	RVT6-27	1/4 in.	7/8 in.	5/8 in.	Aluminum brazier head rivet [top rail to side sheet]
3	RVT6-266	1/4 in.	5/8 in.	5/8 in.	Aluminum brazier head rivet [side sheet to side sheet]
4	RVT1-266	1/4 in.	5/8 in.	1/2 in.	Aluminum universal head rivet [side sheet to side sheet]
5	BLTF8721668-96	3/8 in.	1 in.	Thread: 16	Button head base rail bolt [bottom rail to crossmembers]
6	NUT-HNUNY806	3/8 in.	-	Thread: 16	Nylon lock nut [bottom rail to crossmembers]

DuraPlate® Logistic Side

Item	Part Number	Diameter	Length	Head Diameter	Description / Attaches
1	RVT6-265	1/4 in.	9/16 in.	5/8 in.	Aluminum brazier head rivet [side post to top rail at non-lap] [side sheet to rear attachment] [side sheet to front crossmember] [side sheet to base rail at non-lap] [side post to top rail at sheet-lap] [side post to base rail at sheet-top]
2	RVT1-263	1/4 in.	7/16 in.	1/2 in.	Aluminum universal head rivet [side sheet to post at lap] [between side post & base rail] [between side post & top rail] [side sheet to side post at non-lap]
3	RVT6-266	1/4 in.	5/8 in.	5/8 in.	Aluminum brazier head rivet [base rail to rear attachment strip]
4	AVD2774-0817	1/4 in.	9/16 in.	-	Aluminum monobolt rivet [center of side post to top rail] [center of side post to base rail]
5	BLT60753162	3/8 in.	1 in.	Thread: 24	Button head base rail bolt [to secure crossmembers to base rail]
6	NUT-HNSNY06	3/8 in.	-	Thread: 24	Nylon lock nut [to secure crossmembers to base rail]

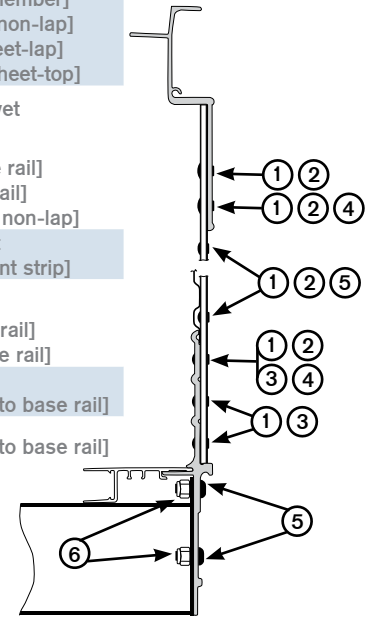

FRP Side

Item	Part Number	Diameter	Length	Head Diameter	Description / Attaches
1	BLT60753008	5/16 in.	1 in.	Thread: 18	Hex head bolt [used to secure top rail to panel] [used to secure front corner post to panel] [used to secure panel to rear attachment post]
2	NUT60752006	5/16 in.	-	Thread: 18	Tee nut [used to secure top rail to panel] [used to secure front corner post to panel] [used to secure panel to rear attachment post]
3	BLT60753101	3/8 in.	1-7/8 in.	Thread: 16	Truss head base rail bolt [used to secure crossmembers to base rail]
4	NUT-HNUNY806	3/8 in.	-	Thread: 16	Tee nut [to secure crossmembers to base rail]

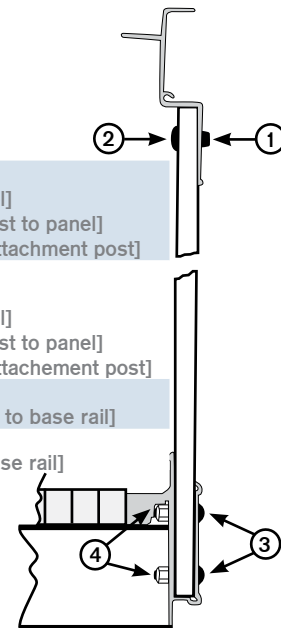

Fasteners Tech

SHP

Pro-Par® Door Fasteners

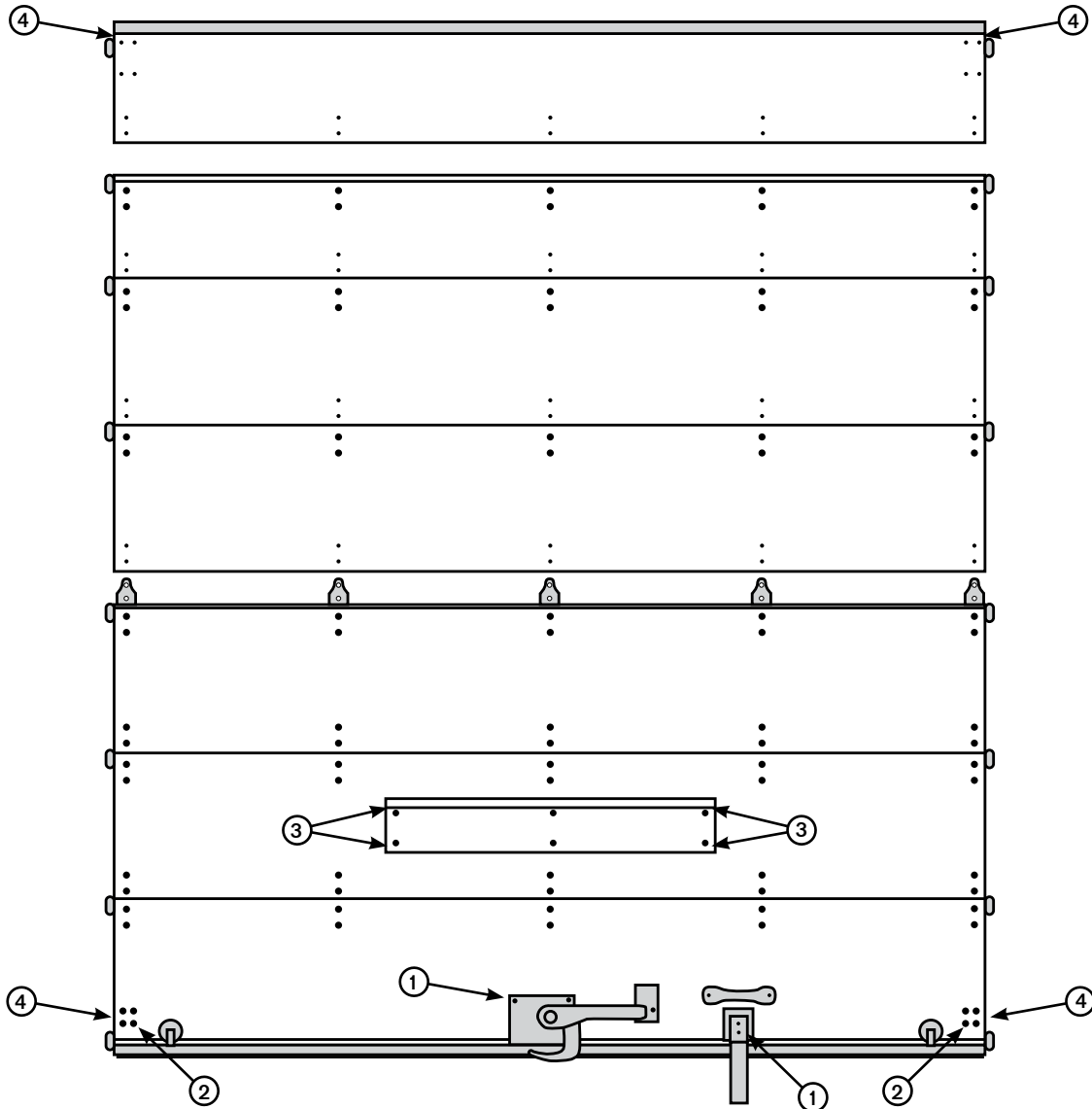

Fasteners Tech

SHP

Item	Part Number	Diameter	Length	Head Diameter	Description
1	RVT10-272	1/4 in.	1-1/8 in.	1/2 in.	Aluminum modified brazier head rivet
2	RVT6-271	1/4 in.	1 in.	5/8 in.	Aluminum brazier head rivet
3	RVT6-28	1/4 in.	15/16 in.	5/8 in.	Aluminum brazier head rivet
4	RVT6-27	1/4 in.	7/8 in.	5/8 in.	Aluminum brazier head rivet
5	SCW6-1250	3/8 in.	1-1/4 in.	-	Plywood screw

Wabash Door Fasteners

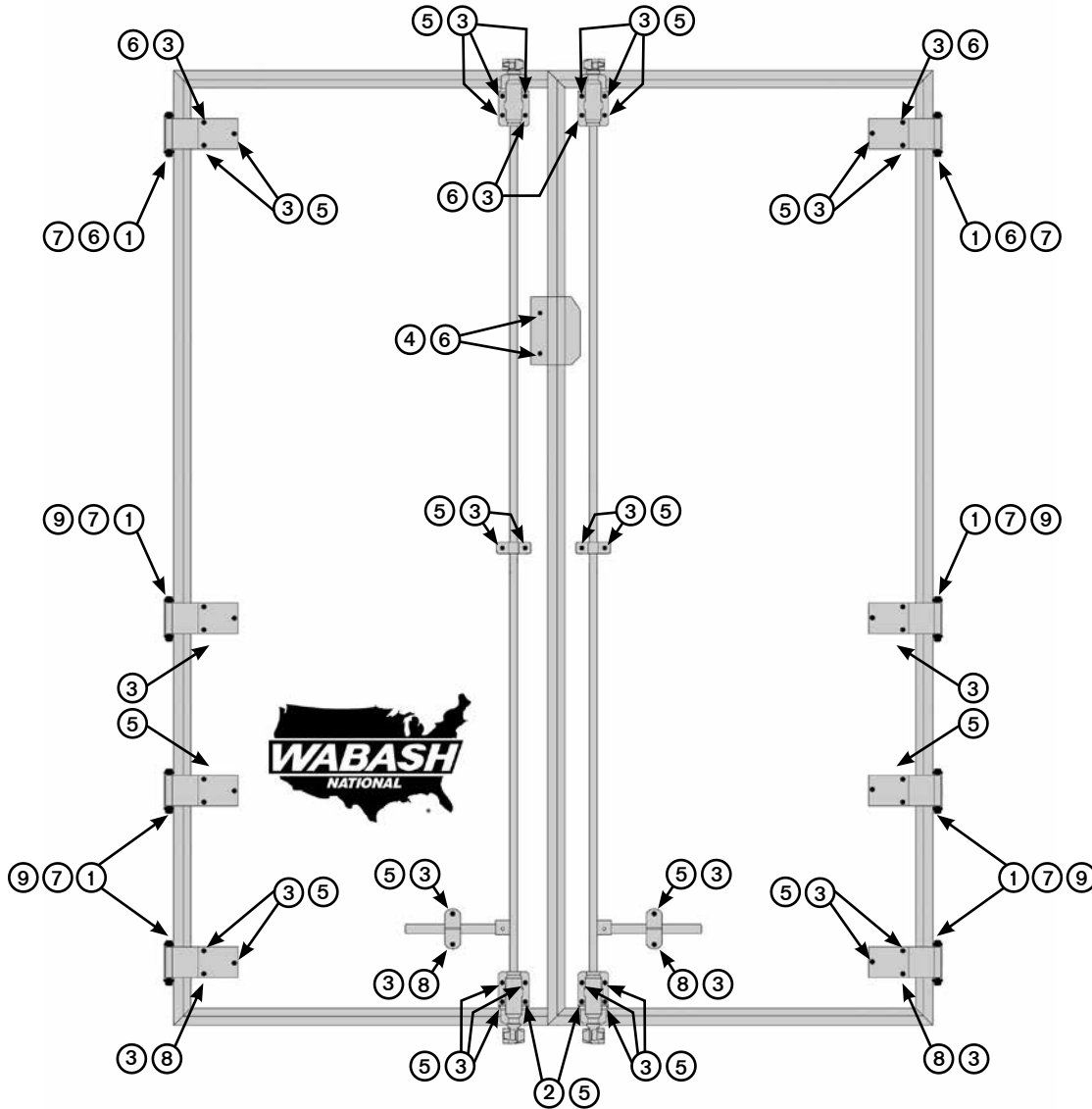

Fasteners Tech

SHP

Item	Part Number	Diameter	Length	Head Diameter	Description
1	BLT1-302	1/2 in.	4-1/2 in.	Thread: 13	Hex head bolt
2	BLT11-201	3/8 in.	1-3/4 in.	Thread: 16	Ribbed neck carriage bolt
3	BLT60753117	3/8 in.	1-1/2 in.	Thread: 16	Button head base rail bolt
4	BLT11-20	3/8 in.	1-1/2 in.	Thread: 16	Ribbed neck carriage bolt
5	NUT-HNUNY806	3/8 in.	-	Thread: 16	Nylon lock nut
6	NUT-HNUNY808	1/2 in.	-	Thread: 13	Nylon lock nut
7	WSH-WWS08	I.D. 1/4 in.	-	O.D. 1-1/16 in.	Zinc plated narrow washer
8	NUT15-1	3/8 in.	-	Thread: 16	Anti-theft nut
9	NUT00752149[^]	1/2 in.	-	Thread: 13	Anti-theft nut
10	TOL1-1	-	-	for NUT15-1	Anti-theft nut socket

[^]Part included for reference only.

Caulk

Adhesive

Silaprene Construction Adhesive SILCONAD



Royal Adhesives

- Saves time by reducing nailing or screw fastening
- 10.1 oz / 24 per case
- Application: Designed to bond gypsum board, FRP, plywood, shearwalls to wood or metal studs

SikaTack - Ultrafast SIK0268243



Sika

- High strength elastic adhesive
- Fast-curing, high-performance elastic gap-filling one-component polyurethane adhesive
- 10.1 oz / 24 per case; Black
- Application: Use when replacing direct glazed automotive glass parts

Sikaflex-252

Part Number Color

SIK252-521 White

SIK252-523 Black

- One-component high strength moisture-curing polyurethane adhesive with high thixotropy
- Bonds & seals at the same time; USDA approved for incidental food contact
- 10.3 fl oz / 24 per case
- Application: Bonds floor to subfloor; Bonds panels to corners or tabular frames; Bonds FRP roofs; Bonds trim & molding

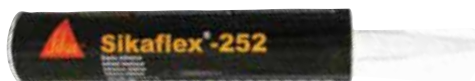

Sika

Adhesive / Sealant

Sikaflex-221

Color / Container

SIK221-521 White / 10.1 fl oz cartridge

SIK221-201 White / Sausage

SIK221-522 Gray / 10.1 fl oz cartridge

SIK221-202 Gray / Sausage

SIK221-523 Black / 10.1 fl oz cartridge

- Multi-purpose, non-sag 1-c polyurethane sealant that cures on exposure to atmospheric humidity to form a durable elastomer
- Application: Use on wood, metals, metal primers & paint coatings, ceramics & plastics



(SIK221-521 / SIK221-522 / SIK221-523)



(SIK221-201 / SIK221-202)

Sika

Caulk

Adhesive / Sealant

Geobond 3500 GEO35101



Geocel

- Polyurethane Bonding Sealant
- Cures to a tough, flexible seal
- 10.1 oz / 24 per case; White
- Application: Concrete, brick, wood, tile, steel, asphalt shingles, and other common building substrates

Transport & Industrial Adhesive Sealer MASVITI987



Vanguard, Inc.

- Outstanding adhesion to most trailer manufacturing materials
- Provides exceptional weathering & waterproofing characteristics
- 11 oz / 24 per case; White
- Application: Adheres to fiberglass, metal, wood, most plastics & urethane foam

Manus-Bond 25AM

	Color
MAN25AM-WHITE	White
MAN25AM-GRAY	Gray

- Fast cure, high strength adhesive/sealant
- Highly weather resistant & can be painted with most paints
- 10.3 fl oz / 36 per case
- Application: Adheres to aluminum, brass, steel, glass, mortar, concrete, wood & many plastics



Manus

Manus-Prene 65-A

	Color
MAN65A-WHITE	White
MAN65A-ALUMINUM	Aluminum

- Adhesive/sealant with exceptional strength, durability, flexibility & adhesion characteristics
- 10.3 fl oz / 36 per case
- Application: For permanent weather-tight bonding & sealing of wood, metal, fiberglass & plastics



Manus

Geocel
Sealants & Adhesives

SHP

Caulk

Adhesive / Sealant

Manus-Bond 73-A

	Color
MAN73A-CLEAR	Clear
MAN73A-WHITE	White
MAN73A-ALUMINUM	Aluminum
MAN73A-BLACK	Black

- Silicone elastomeric adhesive/sealant; Fast cure
- Resistance to weathering & temperature extremes
- 10.3 fl oz / 36 per case
- Application: Designed for bonding & sealing with structural materials



Manus

Manus-Bond 75-AM

	Color / Container
MAN75AM-WHITE	White / 10.1 fl oz cartridge
MANS75AMW2	White / 20 oz Sausage
MAN75AM-GREY	Gray / 10.1 fl oz cartridge
MAN75AM-BLACK	Black / 10.1 fl oz cartridge

- High performance, one-part adhesive/sealant
- Paintable; Fast cure; Industrial grade
- 10.1 fl oz / 30 per case
- Application: Adheres to aluminum, brass, steel, glass & wood



Manus

Silaprene SolidSeal Adhesive

	Color
SIL12176WHITE	White
SIL12154GREY	Gray

- High solids-low voc adhesive/ sealant
- Paintable, sandable, non staining; Waterproof, remains flexible
- 10.3 oz / 12 per case
- Application: Adheres plywood to wood, steel & aluminum



Royal Adhesives

Estimator

Caulk

Joint Size Width x Depth (inches)	Linear Feet Sealed*		Joint Size Width x Depth (inches)	Linear Feet Sealed*		Joint Size Width x Depth (inches)	Linear Feet Sealed*	
	10.3 fl. oz. Cartridge	20 oz. Sausage		10.3 fl. oz. Cartridge	20 oz. Sausage		10.3 fl. oz. Cartridge	20 oz. Sausage
1/2 x 1/4	12	24	1/2 x 3/8	8.3	16	1/2 x 1/2	6.2	12
3/4 x 1/4	8.3	16	3/4 x 3/8	5.5	10.7	3/4 x 1/2	4.1	8.0

Caulk

Adhesive / Sealant

Transportation Adhesive

	Color
SIL12231	White
SIL12084	Gray

- High resistance to UV light, heat & moisture
- Fast drying, paintable; remains flexible
- 10.1 oz / 12 per case
- Application: Use in lap seams; Use for perimeter sealing of windows & doors; Bonds similar & dissimilar materials



Royal Adhesives

Silaprene Adhesive

	Color
SIL6328	White
SIL6325	Gray

- Premier one-part product
- Versatile & durable; Withstands broad temp range
- Resistant to moisture, heat, chemicals & vibration
- 10.1 oz / 24 per case
- Application: Adheres to a variety of surfaces



Royal Adhesives

Sealant

Manus-Bond 30-A

	Color
MAN30A-WHITE	White
MAN30A-ALUMINUM	Aluminum

- Semi-self-leveling, one part, quick drying, synthetic rubber-based seam sealer
- excellent weather resistance & sealing capabilities
- 10.3 fl oz / 36 per case
- Application: Adheres to aluminum, steel, wood, & many plastics



Manus

Caulk

Sealant

Manus-Bond 501-A

	Color
MAN501-A-WHITE	White
MAN501-A-ALUMINUM	Aluminum

- General purpose butyl sealant
- Superior weather resistance & sealing properties
- 10.3 fl oz / 36 per case
- Application: Excellent adhesion to aluminum, steel, wood, glass, plastics and cement



Manus

TremoPro 635

	Color
MAM635W	White
MAM635G	Gray

- High-performance, low-to-medium modulus, one-component, gun-grade polyurethane sealant
- 10.1 fl oz / 30 per case
- Application: Adheres a wide variety of substrates, including ferrous & non-ferrous metals, composite materials & many plastic rubber substrates



Tremco

Sikaflex-227 SIK227-521



- Fast-curing, fast-skinning polyurethane based, elastomeric adhesive/sealant
- Moisture-cured, non-sag system
- 300 ml; White
- Application: Waterproofing exterior lap seams, exposed and concealed joints and expansion joints

Sika

Sealants & Adhesives

TREMCO

Sika

SHP

More Information

Material Safety Data Sheets

Information:

SDS (Safety Data Sheet) documents give detailed information about the nature of a chemical, such as physical and chemical properties, health, safety, fire, and environmental hazards of a chemical product.

Current:

Visit www.MyAuroraPlus.com to download up-to-date SDS documents. Found under the Inquiries tab.

Sealer

Adhesives

Super Weatherstrip & Gasket Adhesive
MMM08001



3M

- Strong, flexible, rubbery adhesive
- Exceptional bond strength; Fast drying
- 5 fl oz / 6 per case; yellow
- Application: Used to bond automotive weatherstripping and is a great adhesive for holding paper, cork, or rubber gaskets in place during installation.

Super Weatherstrip Adhesive
PTX81731



Permatex

- Superior adhesive; Waterproof
- Withstands extreme temperatures
- 5 fl oz / 12 per case
- Application: Use on rubber, metal, auto or van carpeting & fabric-backed vinyl upholstery

Steel Weld™
PTX84332



Permatex

- Sets in 5 minutes and cures in 1 hour
- NSF Certified safe
- 2 oz
- Application: Stripped threads, rust damage, steel components, anchors, and cracks or voids in metal

SikaFast® 3131S
SIK192439



Sika

- High Strength
- Fast Setting and Curing
- 490 ml dual cartridge
- Application: Suitable for bonding sidewall panels; roofs, floors and parts made of aluminum, stainless or galvanized steel and fiber reinforced polymers

SEA-LOK Corner Tab Adhesive
WHIML2001



Whiting

- 4 oz
- Application: Corner door tabs to mitered corners of SEA-LOK panel edge



SHP

Sealants & Adhesives

Sealer

Floor Sealant

Floor Restore - Clear

KEYEC1055ABSF

Size
Covers 48 ft trailer

KEYEC53AB

Covers 53 ft trailer



- Epoxy system that fills gouges, small cracks and delaminations & waterproofs
- Reinforces the wood and is tough enough to stand up to punishing cargos
- Application: Squeegee applied for deep wood penetration

Key Polymer

Sealants & Adhesives

KEY POLYMER

SHP

Preserve, Protect & Repair
Your Wood Trailer Floors



Refurbished Floors

- "It Saves the Floor and Seals the Floor!"
- Adds Years to Performance and Appearance of Used Trailer
- Trailer Ready for Road in 24 Hours

New Floors

- High Value Offering to New Trailer Buyers
- Profitable Upsell
- Customers Will Thank You for Offering
- Very Easy to Apply



- Durable Traction Additive
- Adds Minimal Material & Labor Cost to Floor Restore Installation
- Proven Effective by ANSI Test Methods (American National Standards Institute)



- Permanently Seals Through-holes and Daylight Gaps
- Indestructible Filler for Sealing Around Sectioning
- Eliminates Trip Hazards and Pooling of Wash Out Water
- Easy to Mix and Apply

Add Years to
the Life of Your
Trailer for 1/10
the Cost of a
New Floor!



- "High Gloss Finish" That Customers Love
- Highly Durable — Stands Up to Years of Service
- Makes It Easy to Load & Unload

See Quick Videos: www.keytransportationproducts.com



Shop Supplies

Sealer

Floor Sealant

Key Crack Filler

	Kits
KEYFP100AB	3 - 1 qt.
KEYQP300	1 qt.

Restoration of some damaged wooden trailer floors requires filling of deep gouges & cracks; formulated to handle those tough filling applications while remaining fully compatible with floor restore coatings; applied with a putty knife



Key Polymer

Gasket Maker

Sensor-Safe Blue RTV Gasket Maker

	Size
PTX80022	3 oz.
PTX81860	7.25 oz. PowerBead Can

- Silicone gasket maker; Easy trigger dispensing
- Safe for oxygen sensors
- Reliable "formed-in-place" gaskets that resist cracking, shrinking & migrating
- Application: Replaces almost any cut gasket; Coats pre-cut gaskets to increase reliability



Permatex

High-Temp Red RTV

	Size
PTX81160	3 oz.
PTX85915	7.25 oz. PowerBead Can

- Silicone gasket maker
- Formulated for high temp applications
- 650°F intermittent; remains flexible
- Application: Replaces almost any cut gasket; Coats pre-cut gaskets to increase reliability



Permatex

Storage for Unused Product

RTV Gasket Maker

Silicone Plug

Create by allowing excess material to extend beyond the nozzle to cure, sealing & protecting. For reuse, simply remove the cured product from the tip.

PowerBead™

Store using the silicone plug or using the included plastic cap.

KEY POLYMER

Permatex

SHP

Sealants & Adhesives

Sealer

Gasket Maker

RTV Silicone Adhesive Sealant

	Color
PTX80050	3 oz
PTX85913	7.25 oz. PowerBead Can

- General purpose RTV indoor/outdoor sealant
- Seals, bonds, repairs, mends & secures
- Clear
- Application: Adheres to glass, metal, plastics, fabric, vinyl, weather stripping & vinyl tops



(PTX80050)



(PTX85913)

Permatex

High-Temp Ultra Black RTV

	Size
PTX82180	3.35 oz.
PTX85080	9.5 oz. PowerBead Can

- Silicone gasket maker; Maximum oil resistance
- Sensor safe; Fast curing formula
- Resists temps up to 500°F intermittent
- Application: Replaces almost any cut gasket; Ensures extended drivetrain warranty compliance



(PTX82180)



(PTX85080)

Permatex

Form-A-Gasket No. 2 Sealant

PTX80016



- Permatex
- Slow-drying, non-hardening sealant
 - Resists common shop fluids & fuels
 - 3 oz / 12 per case
 - Application: Use for sealing cut gaskets & stamped parts

Anaerobic Gasket Maker

PTX51813



- Permatex
- Noncorrosive gasketing material
 - Ideal for on-the-spot & emergency repairs
 - 1.69 fl oz / 24 per case
 - Application: Designed for use on aluminum, iron, & steel flanged mating surfaces

Sealants & Adhesives



SHP

Shop Supplies

Sealer

Gasket Maker

Ultra Grey Rigid High-Torque RTV PTX82194



Permatex

- Sensor-safe, low odor, noncorrosive
- Outstanding oil resistance and joint movement tolerance
- 3.5 oz
- Application: Valve covers, oil pans, automatic transmission pans, intake manifold end seals, timing covers, water pumps, thermostat housings

Roof

Manus-Prene 65-B Roof Repair MAN65B-GALLON



Manus

- Air-dry, brush grade neoprene based sealant
- Excellent adhesion; Weather resistant
- 1 gal / 4 per case; Gray
- Application: Use on aluminum, wood, fiberglass & plastics

Manus-Prene 65-H MAN65-H



Manus

- Neoprene sealer; Trowel grade
- Excellent adhesion; Weather resistant
- 1 gal / 8 per case; Gray
- Application: Sealing properties to concrete, mortar, aluminum, wood & many plastics

Roof Seal 76-AM MAN76AMTG



Manus

- Dries quickly to form a tough durable seal
- Excellent weather resistance & retains its flexibility for years; Self-leveling
- 1 gal / 4 per case; Gray
- Application: Use on trailer roofs

2010 Brushable Repair Coating GEO60700



Geocel

- Brushable repair coating; Stops leaks
- Coats & rustproofs metal surfaces
- 1 gal / 4 per case; Clear
- Application: Excellent adhesion to metal, concrete, & wood

Sealer

Roof

Geobond Roof Repair

Part Number	Size	Color	Additional
GEO70100	1 qt.		
GEO70200	1 gal.	Clear	
GEO70202	1 gal.	Aluminum	
GEO70800	1 qt.	Clear	Kit Includes: 1 qt. roof repair, 2 in. brush, 50 ft. x 4 in. roll of polymesh

- Fibered brushable coating
- Stops leaks immediately
- Prevents rust
- UV light & acid rain resistant
- Application: Specially formulated for heavy duty truck trailer & truck body roof applications



(GEO70800)



(GEO70100)



(GEO70200 / GEO70202)

Geocel

Seal-Gap Roof Sealer
MASAH-55



Seal Gap

- Especially developed to prevent claims from leaky roof seams in highway trailers
- 1 gal / 4 per case
- Application: Use on trailer roofs

TremGard 640
MAM640



Tremco

- Brush on, one-part liquid polyurethane coating
- Tough, adherent waterproof coating on the inside or outside of containers preventing water penetration
- 1 gal / 24 per case; Aluminum
- Application: Use on wood, masonry, & metal as well as to seal rivets & bolts

Luma-Shield HD
Aluminum Roof Coating
MAS5180-1GAL



Truco

- Energy saver; Fibered
- Easy to apply; Guards against rust;
- Reduces interior temperature in the summer
- 1 gal / 8 per case
- Application: Use on trailer roofs

Geocel

SEAL-GAP

TREMCO

SHP

Sealants & Adhesives

Sealer

Thread Sealant

Medium Strength Threadlocker Blue

	Size
PTX09978	1 g pouch
PTX24240	1.22 oz
PTX24010	10 g / Gel

- Locks & seals while preventing loosening due to vibration
- Protects treads from corrosion
- Application: Use on valve covers, water pump, & oil pan bolts



(PTX24240)



(PTX24010)



(PTX09978)

Permatex

High Strength Threadlocker Red

	Size
PTX27100	0.20 oz
PTX27140	1.22 oz
PTX27010	10 g / Gel

- High strength threadlocker for heavy-duty applications 3/8 inch to 1 inch
- Application: Locks studs, bushings, & large fasteners against vibration loosening; Replaces set screws & snap rings



(PTX27140)



(PTX27100)



(PTX27010)

Permatex

High Temperature Thread Sealant

PTX59235



Permatex

- Resists leakage, vibration loosening, moisture, hydraulic fluids and diesel fuels
- Protects against shred or wear like thread seal tape
- 1.69 fl oz
- Application: Use on threaded fittings

High Performance Thread Sealant

PTX56521



Permatex

- Replaces thread seal tap & pipe dopes
- Cures rapidly to withstand 10,000 PSI
- Designed for low & high pressure applications
- 1.69 fl oz
- Application: Use on metal, tapered pipe thread fittings



Permatex®

MADE FOR THE PROFESSIONAL



GASKET MAKERS • THREADLOCKERS
 FAST ORANGE HAND CLEANERS
 SPRAY NINE CLEANER/DEGREASER
 LUBRICANTS • ADHESIVES • SEALANTS
 SPECIALTY REPAIR PRODUCTS



permatex.com

Sealer

Thread Sealant

Thread Sealant with PTFE
PTX80632



Permatex

- Seals and resists pressure in air, oil, diesel fuel and hydraulic systems
- Remains pliable at higher and lower temperatures
- 4 oz
- Application: Air conditioning fittings, temperature sending fittings, hydraulic fittings

PTFE Teflon Thread Seal Tape
TAP3-1



- 0.004 in. x 1/2 in. x 260 in.
- Application: Use to seal pipe threads

Tape

Butyl

Premium Butyl Tape

	Size	Usage Area
MAN64-2A	1/16 in. x 1 in. x 100 ft.	Side Wall
MAN64-2-2A	1/16 in. x 5/8 in. x 100 ft.	Side Wall
MAN64A	1/8 in. x 5/8 in. x 60 ft.	Roof Bow

- Synthetic polymer based adhesive/sealant tape; polysul grip
- Application: Adheres to aluminum, glass, galvanized steel and many other porous & non-porous surfaces



Manus

Butyl Rubber Tape
TAPSTK070067065



Manus

- 1/8 in. x 3/4 in. x 50 ft.
- Application: Adheres to aluminum, glass, galvanized steel and many other porous & non-porous surfaces

Tape

Foam

Single-Coated PVC Foam Tape

	Size
TAP62751004	1/16 in. x 1/4 in. x 200 ft.
TAP62751003*	1/16 in. x 5/8 in. x 200 ft.
TAP1-4*	1/16 in. x 3/4 in. x 200 ft.
TAP62751006*	1/16 in. x 1 in. x 200 ft. (single stick)
TAP62751005*	1/16 in. x 1-1/4 in. x 200 ft.



- Medium density, closed cell, PVC foam
- Best general-purpose waterseal foam
- Pressure-sensitive acrylic, on one side
- Application: Adheres to lap seams between side panels; *Roof to top rail

Double Sided Foam Tape TAPTS-217-B



- 1/16 in. x 3/4 in. x 150 ft.
- Application: Adheres panel to panel or roof to top rail

PVC Foam Tape / Roof Tape TAP42300507



- 3/32 in. x 1 in. x 100 ft.
- Application: Adheres roof to top rail

Foil

Aluminum Foil Tape

	Size
TAP2-1	4 in. x 33 ft. 6 in.
TAP2-2	4 in. x 50 ft.
TAP2-3	6 in. x 33 ft. 6 in.
TAP2-4	6 in. x 50 ft.



- Application: Use anytime you need to join two dissimilar metals (ex. aluminum & steel)

Sealants & Adhesives

SHP

Tape

Foil

Patch Tape

	Size
MAN4WTT	0.06 in. x 4 in. x 50 ft
MAN4X50ALUMA	0.06 in. x 4 in. x 50 ft

- One-sided aluma-foil patch tape for that quick easy patch repair
- Foil with a butyl adhesive backing
- Application: Use anytime you need to join two dissimilar metals (ex. aluminum & steel); body & roof repair



Manus

Foil

Polyken Tape TAP360-45



- 4 in. x 30 ft. roll - 45ML
- Application: Use anytime you need to join two dissimilar metals (ex. aluminum & steel)

Plastic

Mylar Tape TAP1-7



- 4 in. x 216 ft.
- Application: Use anytime you need to join two dissimilar metals (ex. aluminum & steel)

Plastic

PVC Tape

	Size
TAP1-1	3 mm x 3 in. x 216 ft.
TAP1-2	3 mm x 3-1/2 in. x 216 ft.



(TAP1-1)



(TAP1-2)

- Application: Use anytime you need to join two dissimilar metals (ex. aluminum & steel)

Sealants & Adhesives

SHP

Tape

Roof Bow
Roof Bow Tape
TAP569-103796

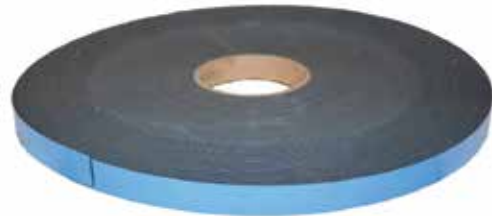

- .045 in. x 3/4 in. x 200 ft.
- Application: Roof to top rail

Electroflex PVC Electrical Tape
TAPAAS000172



- PVC electrical tape; Industrial grade
- Suitable for use at not more than 600 V and not more than 80°C (176°F)
- 3/4 in. x 60 ft.
- Application: Use to insulate for splices up to 600V; Also good moisture protection for irregular surfaces

Utility
Duct Tape
TAPAAA000477



- 2 in. x 180 ft.
- Application: Use for all-around holding, splicing, masking, patching, sealing & seaming

Scotch® Performance Green Masking
MMM26340



- Flexible, conformable backing resists breaking for ease of use,
- Special adhesive resists lifting and edge curl
- 48mm. x 55 m.
- Application: Booth masking, fine lines, general masking, jamb masking, paint preparation

3M™ Automotive Masking Tape
MMM06548



- Sticks to a variety of surfaces including paper, fiberboard, glass, rubber, plastic and metal
- Crepe paper backing is hand tearable
- 48mm. x 55 m.
- Application: Booth masking, general masking, jamb masking, paint preparation

Sealants & Adhesives



SHP

Shop Supplies

Bags

Pro-Par

Part Number	Type	Size
PRO4X6BAG	Reseal, 2 mil	4 in. x 6 in.
PRO6X8BAG	Reseal, 2 mil	6 in. x 8 in.
PRO16X20BAG	Shopping w/ Handles	16 in. x 20 in.

(PRO4X6BAG)



Pro-Par

Part Number	Type	Size
BAG6X8	Plastic	6 in. x 8 in.
BAG6X10	Plastic	6 in. x 10 in.
BAG6X12	Plastic	6 in. x 12 in.
BAG9X18	Plastic	9 in. x 18 in.
BAG16X26	Plastic, 2 Holes at Top	16 in. x 26 in.

(BAG9X18)



Banners

Part Number	Type	Size
PROBANNER	Pro-Par	6 ft. x 2 ft.
PRMAURAUTHBANNER	Aurora Authorized Distributor	6 ft. x 2 ft.
PRMFPBANNER	FleetPreform	6 ft. x 2 ft.



(PROBANNER)

Bins

Plastic Shelf Bin

Part Number	Width	Deep
PROBIN12X4	4 in.	12 in.
PROBIN12X6	6 in.	
PROBIN12X8	8 in.	
PROBIN12X12	12 in.	18 in.
PROBIN18X4	4 in.	
PROBIN18X6	6 in.	
PROBIN18X8	8 in.	
PROBIN18X12	12 in.	



(PROBIN12X12)

Pro-Par

pro-par
OEM Heavy Duty Parts

Marketing

SHP

Bins

Corrugated Shelf Bin

Part Number	Width	Deep
PROBIN12X4X4-CORR	4 in.	
PROBIN12X6X4-CORR	6 in.	12 in.
PROBIN12X8X4-CORR	8 in.	
PROBIN18X4X4-CORR	4 in.	
PROBIN18X6X4-CORR	6 in.	18 in.
PROBIN18X8X4-CORR	8 in.	



(PROBIN18X8X4-CORR)

Pro-Par

Air Fittings

Part Number	Description
PROFBIN-ONLY	Bin with Decal
PROFBIN-STAND	Bin with Stand



Pro-Par

Fasteners

Part Number	Description
BIN-BIN72H	72 Hole, Labels not included



Pro-Par

Quick Reference

Supplier Catalogs

Looking for a Supplier Catalog?

Find out what's available through MA+ or contact your Customer Service Representative.

Search by:

1. Select Part Search
2. Change Category to Marketing & Sales Product
3. Change Sub Category to Catalogs
4. Type in supplier desired in Description box.

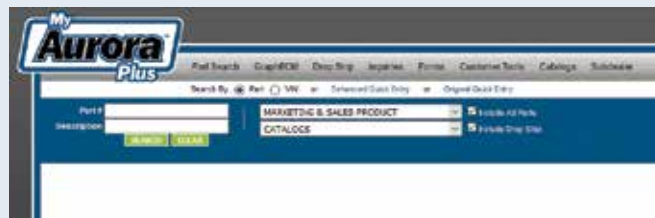

Shop Supplies

Catalogs

Pro-Par

Part Number	Description
PROBFCATALOG	Air Fittings
PROCATALOG	Brake Parts
PROFACATALOG	Fasteners
PROFITCAT2016	Pro-FIT Parts



(PROFACATALOG)

Note: Part numbers subject to change with new editions.

Charts

Pro-Par

Part Number	Description
PROBFWCHART	Air Fittings Wall Chart
PROBSWCHART	Brake Shoe Wall Chart



(PROBFWCHART)



(PROBSWCHART)

Part Number	Description
CRS457627	Scott Seal Interchange Chart
HDXL60063	Haldex Valve Wall Chart, 2 ft. x 3 ft.
MINWALLCHART	Powerbrace Cam and Keepers



(HDXL60063)

Clocks

Pro-Par

Part Number	Description
PROPARCLOCK	Brushed Metal, 14 in.



Decals

Pro-Par

Part Number	Description	Size
DEC1-13	Pro-Par	15 in. x 6 in.
DEC1-14	Fleet Perform	18 in. x 6 in.
DEC1-15	Aurora Authorized Distributor	20 in. x 12 in.
DEC1-16	Aurora Authorized Distributor	39-1/2 in. x 18 in.
DEC1-17	Pro-FIT	12-9/16 in. x 5-1/4 in.



(DEC1-16)



(DEC1-17)



(DEC1-14)



(DEC1-15)



(DEC1-13)

Displays

Pro-Par

Part Number	Description
PROHOSERACK	Hose Rack
PROBUCKETDSPKIT	Bucket Display Kit
PROBARREL1	Barrel, 34 gallon fibre drum
PNTZ-64KIT	Paint Display
PROCHM-64KIT	Chemical Display



(PROHOSERACK)



(PROBARREL1)



(PNTZ-64KIT)

Signs

Part Number	Description	Size
PROEMBSIGNALU	Pro-Par Aluminum Sign	14 in. x 36 in.



More Information

Aurora Authorized Distributor Signs

Looking for an Aurora Authorized Distributor Sign? Contact your Aurora Regional Sales Manager for Details.

Marketing



SHP

Shop Supplies

Samples

Pro-Par

Part Number	Description
PNTSAMPLES	Pro-Par Paint Chip Set



Stools

Pro-Par

Part Number	Description
PRM401-PP	Stool
PRM401-PP-TOP	Stool Top Only



More Information

Pro-Par Website

Need additional information on Pro-Par products?
Visit the Pro-Par website at www.Pro-Par.com.



Abrasives

Green Corps Roloc Disc

Grade	Size	Part Number
36	2 in.	MMM01397
36	3 in.	MMM01407
24	3 in.	MMM01408



- Removes paint, rust & weld
- 25 per box
- Application: Fits any standard 0.25 in. drill or air tool

3M

General Purpose Cut-Off Wheel MMM01987



- Aluminum Oxide
- 3 in. x 1/16 in x 3/8 in. / 50 per case
- Application: For use on utility type cut-off tools for cutting sheet metal, frame rails, exhaust pipes, clamps & rusted bolts

3M

Scotch-Brite Roloc Surface Conditioning Disc

Part Number	Diameter	Grade	Color
MMM07480	2.00 in.	Coarse	Brown
MMM07481	2.00 in.	Medium	Maroon
MMM07485	3.00 in.	Coarse	Brown
MMM07486	3.00 in.	Medium	Maroon



- 25 per box
- Removes light rust, oxides and coatings
- Aluminum Oxide

3M

Application Chart Abrasive Materials

	Aluminum Oxide		Silicon Carbide		Zirconia-Alumina	Ceramic	
	Coated	Non-Woven	Coated	Non-Woven	Coated	Coated	Non-Woven
Ferrous							
Carbon Steel	Better	Better		Good	Better	Best	Best
Alloy Steel	Good	Better		Good	Better	Best	Best
Stainless Steel	Good	Better		Good	Better	Best	Best
Cast Iron	Better	Better		Good	Better	Best	Best
Non Ferrous							
Aluminum Alloys	Best	Best	Better		Good	Better	Best
Brass, Bronze, Copper, Zinc	Best	Best	Best		Good	Better	Best
Titanium	Better	Best			Better	Best	Best
Plastic	Best	Best	Best	Better	Better	Good	
Wood	Best		Better			Good	

Abrasives

Cut Off Wheel

	Size
TOLMBO55317	3.00 in. x 0.04 in. x 3/8 in.
TOLMBO55327	4.00 in. x 1/16 in. x 3/8 in.
TOLMBO55331	4-1/2 in. x 0.04 in. x 7/8 in.



Flap Disc TOLMBO24241



- Zirconia, 40 grit
- 4-1/2 in. x 7/8 in.
- Application: Processing fillet welds and surface grinding

Cleaners

Hand Cleaner

Fast Orange Hand Cleaner Wipes PTX25051



Permatex

- Removes the toughest grease, tar, grime, ink, paints, sealants, adhesives & other difficult soils
- Textured one side for heavy duty cleaning & smooth side for general purpose cleaning
- 10-1/2 in. x 12-1/4 in. / 72 count bucket

Fast Orange Pumice Lotion Hand Cleaner PTX25219



Permatex

- #1 selling, biodegradable, waterless, petroleum solvent-free hand cleaner that contains no harsh chemicals, mineral oils or ammonia that can sting cuts and abrasions
- Pure, fresh-smelling natural citrus power does the cleaning; gently deep cleans the toughest dirt
- 1 gallon with pump

Cleaners

Scott Shop Towels

Size	
Box of 12 Rolls	SHPS-14769
Box of 200	SHPS-12809



- Around the shop handy towels that absorb liquids, oil & grease

Towels

Shop Rags
SHP-RAG



- Soft colored knits
- 50 lb box

Oil Dri Premium Absorbent
OILI06032



- Clay absorbents
- Absorbs oil, grease, hydraulic fluid, water & other liquid spills
- Minimal dust & rapid absorption power
- Can reduce slipping accidents & hazards
- 40 lb bag / Qty: 50

Oil Dri

Heavy Weight Absorbent Pad
OILL90902-BOX



- Safely absorbs all fluids
- Pads are made of treated chemically inert meltblown polypropylene
- Bonded layers allow flow to spread through the material for a quicker absorption rate
- 15 in. x 19 in. / 100 pads per box

Oil Dri

Universal Absorbent Bucket Kit

	Size
OILL90435	5 gal

- Includes: (2) 48 in. socks, (10) perforated pads, (1) disposal bag, (1) tie, (1) 5 gal. bucket with kit



Oil Dri

Oil Dri
CORPORATION OF AMERICA
Supplies
SHP

Personal Safety

Ear Plugs

Classic E-A-R Earplug
MMM310-1001



3M

- Uncorded; 29 decibel noise reduction rate
- Moisture resistant; Flame retardant;
- Reduced pressure, lower equilibrium pressure
- 200 per case

Glasses

Virtua Clear Hardcoat Lens
MMM11326



3M

- Polycarbonate construction with a hard coat, scratch resistant; Designed for indoor use
- Lightweight lens with a sleek, contoured fit
- Cost effective; high wrap around coverage
- 20 per case

Gloves

Knit Gloves

Size	
Small	GLV1775-S
Medium	GLV1775-M
Large	GLV1775-L
XL	GLV1775-XL



Kinco

- HD poly cotton string knit; Reversible thumb

9 oz Brown Jersey Gloves

Size	
Small	GLV820-S
Large	GLV820-L
XL	GLV820-XL



Kinco

- Knit wrist; Clute cut

Gray Suede Cowhide Leather Work Gloves

Size	
Medium	GLV1500-M
Large	GLV1500-L
XL	GLV1500-XL



Kinco

- Cowhide leather palm; Rubberized safety cuff

Nylon Black Deer Palm Lined Grain Leather Work Gloves

Size	
Medium	GLV101HK-M
Large	GLV101HK-L
XL	GLV101HK-XL



Kinco

- Grained deerskin with Heatkeep lining
- Easy-on open cuff with shirred elastic on wrist

3M

Kinco

Supplies

SHP

Personal Safety

Unlined Grain Deerskin Leather Work Gloves

Size	
Small	GLV90-S
Medium	GLV90-M
Large	GLV90-L
XL	GLV90-XL



Kinco

- Premium grade leather
- Shirred elastic back; Keystone thumb

Gloves Cowhide Grain Drivers Leather Work Gloves

Size	
Medium	GLV98-M
Large	GLV98-L
XL	GLV98-XL
2XL	GLV98-XXL



Kinco

- Unlined grain cowhide
- Keystone thumb; Shirred elastic back

KincoPro™ Unlined Grain Goatskin Leather Driver

Size	
Medium	GLV103-M
Large	GLV103-L
XL	GLV103-XL



Kinco

- Form fitting stretchable synthetic back
- Pearl goatskin leather
- Easy-On™ open cuff with elastic wrist
- Neoprene knuckle strap for added protection

Application Chart

Protective Gloves

Chemical	Neoprene	Latex/Rubber	Butyl	Nitrile
Acetone*	Good	Very Good	Very Good	Poor
Diesel Fuel	Good	Poor	Poor	Very Good
Gasoline, Leaded & Unleaded	Good	Poor	Fair	Very Good
Hydrofluoric Acid (48%)	Very Good	Good	Good	Good
Phosphoric Acid	Very Good	Good	Very Good	Very Good
Sodium Hydroxide	Very Good	Very Good	Very Good	Very Good
Sulfuric Acid	Good	Good	Good	Good
Toluene*	Fair	Poor	Poor	Fair
Trichloroethylene*	Fair	Fair	Poor	Good

Generally, the thicker the glove material, the greater the chemical resistance

Chemicals marked with an asterisk (*) are for limited service.

Supplies



SHP

Personal Safety

Gloves

Disposable Latex Gloves

	Size
PTX09182	Large
PTX09183	XL



- Natural Latex; Textured fingers
- Fit either hand
- Lightly Powdered
- 100 count box

Permatex

Disposable Blue 4 mil Nitrile Gloves

	Size
PTX09185	Large
PTX09186	XL



- 100% Synthetic Rubber; Textured fingers
- Lightly Powdered
- Suitable for users with sensitivity to natural rubber latex
- Superior Chemical Resistance
- 100 count box

Permatex

Masks

**8511 N95 Particulate
Welding Respirator
MMM07185**



- Lightweight, two-strap filtering facepiece respirator
- Designed for use in grinding, sanding & buffing applications
- Features 3M™ Cool Flow™ Valve & adjustable M-noseclip for added comfort

3M

**8515 N95 Particulate
Welding Respirator
MMM07189**



- Economical N95 disposable particulate welding respirator
- Helps provide respiratory protection for applications where metal fumes may be present
- Features 3M™ Cool Flow™ Valve, braided headband and adjustable M-noseclip for added comfort

3M

Personal Safety

Masks

N95 Particulate Respirator
MMM07048



- Designed for use in grinding, sanding & buffing application
- Lightweight, two-strap filtering facepiece respirators with adjustable noseclip & new braided headstraps
- Box of 20

3M

Replacement Particulate Filter, P100
MMM07184



- Nuisance level organic vapor relief
- Exceptional 99.97% filter efficiency meets NIOSH P100 series test criteria
- Versatile protection against many oil and non-oil based particulate contaminants
- Box of 100

3M

NOTE: N Series = used in environments free of oil aerosols

Application Chart
Particulate Respirator

National Institute for Occupational Safety & Health (NIOSH)

Particulate filtering facepiece respirators protect by filtering particles out of the air the user is breathing. NIOSH tests and certifies respiratory protective devices, and purchases certified products on the open market to verify continued compliance.

NIOSH Respirator Labeling

1. NIOSH testing and certification approval number, e.g. TC-84A-XXXX
2. Name of approved manufacturer
3. NIOSH in block letters or the NIOSH logo
4. Model Number
5. Lot Number
6. NIOSH filter series and filter efficiency level, e.g. N95, N99, N100, R95, P95, P99, P100

NIOSH Designations	Filtered Airborne Particles	Resistant To Oil
N95	95%	Not
N99	99%	Not
N100	99.97%	Not
R95	95%	Somewhat
P95	95%	Strongly
P99	99%	Strongly
P100	99.97%	Strongly

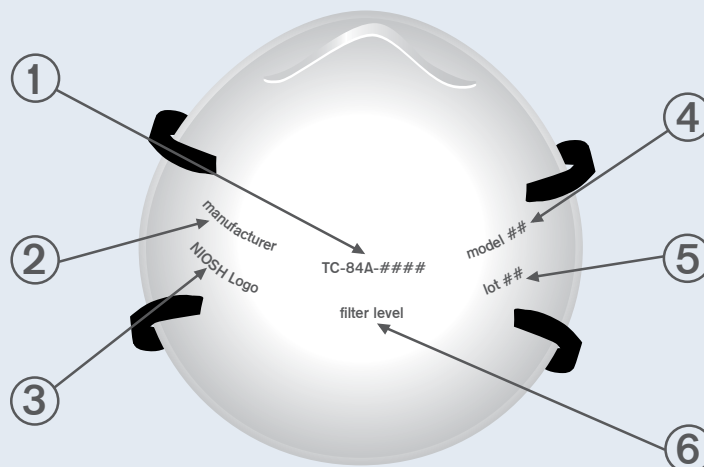

Supplies
3M
SHP

Bits

Drill

Brute XL28 Mechanics

	Diameter	Flute Length	Overall Length	Champion Number
DRLBR-188	3/16 in.	1-7/8 in.	3.00 in.	XL28-3/16
DRLBR-203	13/64 in.	1-15/16 in.	3-1/8 in.	XL28-13/64
DRLBR-219	7/32 in.	2.00 in.	3-1/4 in.	XL28-7/32
DRLBR-250	1/4 in.	2.00 in.	3-1/2 in.	XL28-1/4
DRLBR-266	17/64 in.	2-1/8 in.	3-5/8 in.	XL28-17/64
DRLBR-281	9/32 in.	2-1/4 in.	3-3/4 in.	XL28-9/32
DRLBR-312	5/16 in.	2-1/2 in.	4 in.	XL28-5/16
DRLBR-375	3/8 in.	2-11/16 in.	4-1/4 in.	XL28-3/8

- Mechanics length drills
- Three-flat shank design ensures a positive grip in both keyless & conventional power tools
- Overall length provides added strength and rigidity



Champion

BlackGold XGO Jobber

	Diameter	Flute Length	Overall Length	Champion Number
DRLBG-062	1/16 in.	7/8 in.	1-7/8 in.	XGO-1/16
DRLBG-078	5/64 in.	1 in.	2 in.	XGO-5/64
DRLBG-094	3/32 in.	1-1/4 in.	2-1/4 in.	XGO-3/32
DRLBG-109	7/64 in.	1-1/2 in.	2-5/8 in.	XGO-7/64
DRLBG-125	1/8 in.	1-5/8 in.	2-3/4 in.	XGO-1/8
DRLBG-141	9/64 in.	1-3/4 in.	2-7/8 in.	XGO-9/64
DRLBG-156	5/32 in.	2 in.	3-1/8 in.	XGO-5/32
DRLBG-172	11/64 in.	2-1/8 in.	3-1/4 in.	XGO-11/64
DRLBG-188	3/16 in.	2-5/16 in.	3-1/2 in.	XGO-3/16
DRLBG-194	0.1935 in.	2-7/16 in.	3-5/8 in.	XGO-10
DRLBG-196	0.1960 in.	2-7/16 in.	3-5/8 in.	XGO-9
DRLBG-203	13/64 in.	2-7/16 in.	3-5/8 in.	XGO-13/64
DRLBG-219	7/32 in.	2-1/2 in.	3-3/4 in.	XGO-7/32
DRLBG-234	15/64 in.	2-5/8 in.	3-7/8 in.	XGO-15/64
DRLBG-250	1/4 in.	2-3/4 in.	4 in.	XGO-1/4
DRLBG-257	0.2570 in.	2-7/8 in.	4-1/8 in.	XGO-F

	Diameter	Flute Length	Overall Length	Champion Number
DRLBG-261	0.2610 in.	2-7/8 in.	4-1/8 in.	XGO-G
DRLBG-266	17/64 in.	2-7/8 in.	4-1/8 in.	XGO-17/64
DRLBG-281	9/32 in.	2-15/16 in.	4-1/4 in.	XGO-9/32
DRLBG-297	19/64 in.	3-1/16 in.	4-3/8 in.	XGO-19/64
DRLBG-312	5/16 in.	3-3/16 in.	4-1/2 in.	XGO-5/16
DRLBG-328	21/64 in.	3-5/16 in.	4-5/8 in.	XGO-21/64
DRLBG-344	11/32 in.	3-7/16 in.	4-3/4 in.	XGO-11/32
DRLBG-359	23/64 in.	3-1/2 in.	4-7/8 in.	XGO-23/64
DRLBG-375	3/8 in.	3-5/8 in.	5 in.	XGO-3/8
DRLBG-391	25/64 in.	3-3/4 in.	5-1/8 in.	XGO-25/64
DRLBG-406	13/32 in.	3-7/8 in.	5-1/4 in.	XGO-13/32
DRLBG-422	27/64 in.	3-15/16 in.	5-3/8 in.	XGO-27/64
DRLBG-438	7/16 in.	4-1/16 in.	5-1/2 in.	XGO-7/16
DRLBG-453	29/64 in.	4-3/16 in.	5-5/8 in.	XGO-29/64
DRLBG-469	15/32 in.	4-5/16 in.	5-3/4 in.	XGO-15/32
DRLBG-500	1/2 in.	4-1/2 in.	6 in.	XGO-1/2

- Heavy duty XGO BlackGold drills out perform ordinary jobber drills by penetrating faster & lasting longer
- Black & gold surface treatment holds lubricant for smoother drilling



Champion

Screw Machine Drill Bit

	Diameter	Flute Length	Overall Length	Champion Number
DRLSM-194	0.1935 in.	1-3/16 in.	2-1/4 in.	1705-10

- Heavy duty, split point bit
- Better hole accuracy and longer tool life, even on difficult materials such as stainless steel or heavy duty applications



Champion

Tools



SHP

Bits

Holders

Part Number	Bit Size	Drive	Overall Length
TOL858	1/4 in.	1/2 in.	1-3/4 in.
TOL838	1/4 in.	3/8 in.	1-1/2 in.
TOL855	5/16 in.	1/2 in.	1-3/4 in.



Phillips

Part Number	Diameter
TOL440-P2	1/4 in.
TOL440-P3	1/4 in.
TOL480-P3	5/16 in.
TOL480-P3	5/16 in.



Torx

Part Number	Size	Diameter
TOL440-TX-20	20	1/4 in.
TOL440-TX-25	25	
TOL440-TX-27	27	
TOL440-TX-30	30	
TOL440-TX-40	40	
TOL440-TX-45	45	5/16 in.
TOL480-TX-30	30	
TOL480-TX-40	40	
TOL480-TX-45	45	
TOL480-TX-55	55	



Application Chart

Rivet Drill Hole Size

Rivet Diameter	Hole Size	Drill Bit
1/8 in.	0.125 - 0.135	DRLBG-125
5/32 in.	0.156 - 0.171	DRLBG-156
3/16 in.	0.187 - 0.202	DRLBG-194
7/32 in.	0.218 - 0.233	DRLBG-219
1/4 in.	0.250 - 0.265	DRLBG-257

Rivet Diameter	Hole Size	Drill Bit
9/32 in.	0.281 - 0.296	DRLBG-281
5/16 in.	0.312 - 0.327	DRLBG-312
11/32 in.	0.343 - 0.358	DRLBG-344
3/8 in.	0.375 - 0.390	DRLBG-375
13/32 in.	0.406 - 0.421	DRLBG-406

Gauges

Dual Foot Truck Service Gauge

Bar	Chuck	Finish	
Nylon	Angled Chuck	Chrome	HALGA-135
Metal	Straight-On 30° Reverse	Chrome	HALGA-155S



Haltec

- Variety of service gauges to accommodate numerous tire and wheel configurations

Cable & Circuit Tester TRU97101



Truck-Lite

- Compliment to the lamp and circuit tester
- Uses high quality brass pins for reliable contact
- LEDs quickly identify faulty circuits in either of the connector cord assembly or the tractor

Kingpin Gauge HOLTF-0110



SAF Holland

- Indicates an undersized condition and need of replacement
- Can also be used to check kingpin length

Wear Gauge Set PRE14000



Premier

- Pintle hook & drawbar eye
- Measures the gap between the top of the coupling hook & the closed latch

How To Use Kingpin Gauge

Inspecting Diameters

1. Slip gauge over kingpin.
2. Position the gauge onto portion of kingpin to be measured.
3. Be sure to rotate the gauge 360 degrees around the kingpin to measure diameter in all direction.
4. Gauge indicates 1/8 in. of wear.

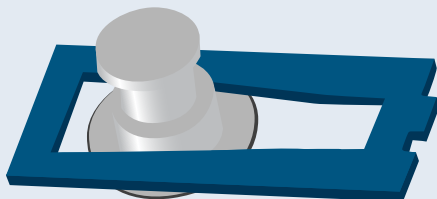

Inspecting Height & Squareness

1. Place the notched end of the gauge onto the kingpin.
2. If kingpin does not fit into gauge, height of kingpin is incorrect or bent.
3. Rotate gauge 360 degrees to check all sides of kingpin.



Trailer Tools

Axle

Socket Wrench
FRUACC5963-900



- For Pro-Par Hub Cap & axle nut

Brake Chamber Caging Tool
MID10043



- Caging tool for brake chamber springs

Oil Seal Installation Tool

Handle (A)	Seal Plate (B)	Bearing Pilot (C)	Seal / Pro-Par	Seal / Red	Seal / Gold
PROWSRD296	PROWSRD307	PROWSRD406	PROWS0001A	370001A	380001A
PROWSRD296	PROWSRD305	PROWSRD416	PROWS0003A	370003A	380003A
PROWSRD296	PROWSRD306	PROWSRD413	PROWS0025A	370025A	380025A
PROWSRD296	PROWSRD310	PROWSRD412	PROWS0065A	370065A	380065A
PROWSRD296	PROWSRD313	RD410	-	370031A	380031A



- All installation tools require the handle, the seal plate, and the bearing pilot for proper seal installation.
- Lube the inside diameter of the seal to install seal on the seal plate.
- Use only the seal manufacturer's installation tool with the seal being used.

Pro-Par

Multi-Purpose

7-Way Cleaning Kit
IMXGT-3201



- For 7-Way sockets and plugs, male and female

Haldex

pro-par
OEM Heavy Duty Parts

Tools

SHP

Trailer Tools

Multi-Purpose

Carrand Cleaning Tools

Part Number	Description
BSH9057	Squeegee, 8 in. Head & 20 in. Handle
BSH92012	Heavy Duty Wheel Brush
BSH92036	Heavy Duty Wheel and Bumper Brush
BSH92508	Fiberglass Pole, 4 ft. to 8 ft. Adjustable
BSH92509	Fiberglass Pole, 6 ft. to 12 ft. Adjustable
BSH92510	Fiberglass Pole, 6 ft.
BSH93039	Long Handle Dip Brush, 20 in. Long

Part Number	Description
BSH93078	Brush Head, 10 in.
BSH93079	Bi-Level Brush Head, 10 in
BSH93502	Wooden Pole, 6 ft.
BSH93505	Stack Brush Head, 4 in. or 6 in.
BSH9514	Aluminum Pole, 8-1/2 ft. Adjustable
BSH9603	Rolling Display Rack
BSH9603HD	Bulk Brush & Pole Prepack, includes rack



(BSH9057)



(BSH92036)



(BSH93078)



(BSH93079)



(BSH92510)

United Marketing

Body

Door Track Tweakster

Part Number	Size
TOL1311	1 in.
TOL1312	2 in.

- Repair crushed, bent, twisted trailer door tracks
- Hammer it through a crushed track section to open it up
- Use the slot to tweak the edges back into shape
- Pry track open with the slot to replace rollers & close the track again



(TOL1312)



(TOL1311)

Rivet Setting Tool

	Shaft
TOLSM10-4558-45610	0.401 in.
TOLSM30-4558-45610	0.498 in.



(TOLSM10-4558-45610)



(TOLSM30-4558-45610)

Trailer Tools

Suspension

Bushing Tool
MTRA3256-H-1152



Meritor

- Control arm bushing tool

Bushing Tool
HENS-21307



Hendrickson

- For S-6914 & S-24691 bushing installation
- Wide bushing

Bushing Tool
HENS-24736



Hendrickson

- For S-26321 & S-24705 bushing installation
- Narrow bushing

Socket E-20
HENS-24303



Hendrickson

- For suspension alignment bolt



Tools

SHP